



Aircraft Fueling Procedures Manual

©1991, 2024 by Piedmont Airlines, Inc. Salisbury, MD 21804

All rights reserved. No part of this publication may be reproduced or transmitted in any form or by any means, electronic or mechanical, including photocopy, recording, or any information storage and retrieval system, without prior written permission from Piedmont Airlines, Inc.

Record of Revisions

Rev. No.	Effective Date	Rev. No.	Effective Date	Rev. No.	Effective Date	Rev. No.	Effective Date
00		20		40		60	
01	15 DEC 91	21		41		61	
02	18 OCT 95	22		42		62	
03	10 FEB 98	23		43		63	
04	23 APR 99	24		44		64	
05	01 APR 01	25		45		65	
06	18 MAR 09	26		46		66	
07	21 MAR 14	27		47		67	
08	21 MAR 15	28		48		68	
09	20 OCT 15	29		49		69	
10	12 MAY 16	30		50		70	
11	13 MAR 19	31		51		71	
12	02 JUN 20	32		52		72	
13	18 NOV 20	33		53		73	
14	08 JUN 21	34		54		74	
15	14 SEP 23	35		55		75	
16	30 JUL 24	36		56		76	
17	30 SEP 24	37		57		77	
18		38		58		78	
19		39		59		79	

List of Effective Pages

Record of Revisions

i 30 SEP 24

Record of Alert Bulletins

i 30 SEP 24

List of Effective Pages

i 30 SEP 24

ii 30 SEP 24

Highlights

i 30 SEP 24

Chapter 1: Introduction

i 02 JUN 20

1 02 JUN 20

2 14 SEP 23

3 02 JUN 20

4 02 JUN 20

5 18 NOV 20

6 02 JUN 20

7 30 SEP 24

8 30 JUL 24

Chapter 2: Safety

i 30 SEP 24

1 14 SEP 23

2 13 MAR 19

3 13 MAR 19

4 18 NOV 20

5 13 MAR 19

6 13 MAR 19

7 13 MAR 19

8 13 MAR 19

9 13 MAR 19

10 13 MAR 19

11 13 MAR 19

12 30 SEP 24

Chapter 3: ATA 103 and Definitions

i 13 MAR 19

1 13 MAR 19

2 13 MAR 19

3 13 MAR 19

4 13 MAR 19

5 13 MAR 19

6 13 MAR 19

Chapter 4: Training and Waiver Procedures

i 14 SEP 23

1 14 SEP 23

2 14 SEP 23

3 30 JUL 24

4 14 SEP 23

5 14 SEP 23

6 14 SEP 23

7 14 SEP 23

8 14 SEP 23

Chapter 5: Embraer EMB-140/145 Fueling Procedures

i 13 MAR 19

1 30 JUL 24

2 13 MAR 19

3 13 MAR 19

4 13 MAR 19

5 13 MAR 19

6 13 MAR 19

7 13 MAR 19

8 13 MAR 19

9 13 MAR 19

10 13 MAR 19

11 13 MAR 19

12 13 MAR 19

13 13 MAR 19

14 13 MAR 19

15 13 MAR 19

16 13 MAR 19

17 13 MAR 19

18 13 MAR 19

19 13 MAR 19

20 13 MAR 19

21 13 MAR 19

22 13 MAR 19

23	13 MAR 19
24	13 MAR 19
25	13 MAR 19
26	13 MAR 19
27	13 MAR 19
28	13 MAR 19
29	13 MAR 19
30	13 MAR 19
31	13 MAR 19

Highlights

Additions and Deletions

Added new sections: [2.11 Back-Up Camera Policy](#), [2.11.1 Minimum Requirements](#), [2.11.2 Training and Documentation](#)

Revisions

- * Added a reference to back-up camera under [1.9.1 Rules](#) letter “J”.

Chapter 1: Introduction

1.1 General 1-1

1.2 Responsibilities 1-3

1.3 Aircraft Fueling Procedures Manual Revisions/Upgrades 1-4

1.4 Fuel Requirements 1-4

1.5 Fuel Specifications 1-4

1.6 Switch Fueling 1-5

1.7 Fueling Records..... 1-5

1.8 Overall Process Responsibility 1-5

1.9 General Safety Rules..... 1-7

 1.9.1 Rules 1-7

Chapter 1: Introduction

The following manual has been prepared by Piedmont Airlines Inc. and is intended to assist fuel servicing personal by outlining procedures for receiving, storing and dispensing aviation fuel.

It is your responsibility to know where to find the Piedmont Aircraft Fueling Procedures Manual (AFPM) and how to access it. If you have any questions please ask your companies Piedmont designated trainer or reachout to the Piedmont Quality Assurance department for information. It is also the Fuel Vendors responsibility to comply with any safety rules or guidelines set forth in their associated Airports Required procedures.

☞ Piedmont Technical Publications Department will provide a copy of this manual in paper or electronic format to all Fueling Vendors used by the airline. During audits of new vendors the Quality Assurance department may provide a copy or contact Technical Publications to have a copy sent to the vendor. Replacements for lost manuals will be provided by the Technical Publications Department upon notification by the vendor or Piedmont Quality Assurance.

Piedmont recognizes the tremendous responsibilities of those who are involved in the handling and dispensing of aviation fuel.

The person with the fueling hose occupies a unique position in the aviation industry. The importance of this position should never be overlooked or minimized. The safety of the aircraft, the passengers, and the crews depend upon the skills, knowledge, and ability of the fueler to safely deliver the correct grade of clean, dry fuel into the aircraft. It is one of the prime factors contributing to flight safety.

Due to the large volume requirement of modern aircraft, fuelers are hurried by the cry for more fuel in fewer minutes. They are hampered by the wind and weather, heat and cold, darkness and glare of lights; and yet must guard with unwavering vigilance against the ever present threats of fire and fuel contamination. Finally, the fueler is required to keep accurate records of the important operation he performs.

It goes without saying that here is a position worthy of all the cooperation and guidance we can offer.

This manual and its contents ensure compliance with 14 CFR Parts 121.105, 121.123 and 121.135.

This manual is the responsibility of the Quality Assurance Department. Any changes to this manual will be submitted to the Maintenance Department for acceptance prior to publication in accordance with Technical Publications Manual procedures.

1.1 General

- A. This manual contains inspection and testing procedures applicable to the airport fuel storage and delivery systems which provide fuel to the aircraft of Piedmont.
- B. ☞ Fuel vendors will ensure that competent personnel are employed in the fueling of Piedmont' aircraft. Personnel will be trained on Piedmont's procedures in accordance with the processes called out in [Chapter 4: "Training and Waiver Procedures"](#). In addition each fuel vendor will be required to have a company training program in place for refueling personnel. Records of company and Piedmont specific training must be kept on file for observation during Piedmont Quality Assurance audits.
- C. ☞ Fuel vendors will insure that their refueling facilities, equipment and fuel storage facilities are adequate for refueling Piedmont's aircraft. Piedmont requires that fuel vendors adhere to the latest revision of ATA103 and applicable CFRs to insure that their refueling facilities, equipment and fuel storage facilities are adequate. Fueling vendors are required to possess the latest revision of ATA 103 and applicable CFRs.
- D. ☞ Refueling equipment used in refueling Piedmont aircraft must meet the requirements of ATA 103 applicable FAA CFRs and the aircraft specific chapters of this manual.
- E. The records, equipment and facilities of fuel storage and delivery organization (hereinafter "vendors") should be available for inspections during normal working hours. All fuel inspection records must be signed and retained for a period as specified on the forms.
- F. A waiver to the policies and procedures in this manual that will not compromise fuel quality, safety or security may be granted because of extenuating circumstances. A request for a waiver shall be in writing to the airline and shall contain all pertinent details and reasons why a waiver is required. Approval must be made by the airline and

General

14 SEP 23

shall be in writing. Approvals shall specify an expiration date and any related stipulations. The vendor shall maintain the written waiver on file so long as it is effective. (See Chapter 4.3 Form FVWR, Fuel Vendor Waiver Request, Chapter 4.4 Form FVGW, Fueling Vendor Grant of Waiver, and Chapter 4.6 Communications).

- G. In the case of foreign vendors a single indefinite waiver may be granted upon request where procedures and requirements differ from those described in this manual so long as the vendor complies with the procedures described in its own procedures manual. The differences will be reviewed upon request for waiver and during subsequent audits. At no time, under any circumstances will product of a lesser quality than the standards described herein be put into Piedmont aircraft, nor may Piedmont, its personnel, passengers, equipment, or the goods entrusted to it be jeopardized in any way as a result of these differences.
- H. If, for any reason, a fueling system becomes inoperable so as to impair the airlines' operations, the airline must be notified.
- I. All inspections and tests specified in this manual shall be performed by qualified personnel.
- J. The vendor is responsible for assuring that all fuel handling personnel are properly trained. Written records of employee training shall be maintained on file.
- K. ☞ Fuel which is removed from an aircraft because of possible contamination shall be held in quarantine until laboratory tests have been performed to determine its acceptability.
- L. ☞ Product defueled from an aircraft for purposes other than contamination should be returned to the airline from which it was removed. Defueled product from another source may not be delivered to an American Eagle aircraft without its approval.
- M. Defueling aircraft directly into a joint use hydrant system is not authorized unless the procedure has been unanimously approved by all system users.
- N. . Clean dry sump fuel can be considered aircraft quality and can be returned to airport storage. Prior to returning fuel back to airport storage, handling and testing procedures must be approved by the American Eagle Quality Assurance Department through observation during its normally scheduled audit program.
- O. The vendor shall establish procedures for reporting of any observed deficiencies or safety hazards by its employees to their superiors.
- P. ☞ Revisions to this manual are controlled by Piedmont. Each vendor shall maintain the Revision Log to document insertion of revisions.
- Q. ☞ If visible fuel contamination is observed or found, aircraft refueling must be discontinued from that source. Notify all affected aircraft operators if it is anticipated that such contamination might impact aircraft operations. Fueling shall not be resumed from the system until the source of fuel contamination is found and removed.

1.2 Responsibilities

☞ Aircraft Fueling procedures include the following responsibilities:

- A. Piedmont Quality Assurance personnel are responsible for ensuring the fuel vendor operations are in strict adherence to the procedures and specifications outlined in this manual.
- B. The Fuel Vendor is responsible for:
 1. Ensuring that quality control standards outlined in this manual are met when receiving, storing and dispensing fuel.
 2. Ensuring that all safety standards outlined in this manual are practiced.
 3. Enforcing all Federal, State, and local regulations governing the storage and handling of fuels.
 4. Enforcing aircraft refueling procedures stated herein, including Federal, State and local regulations.
 5. Performing all fuel quality checks and tests (including periodic checks and tests) as specified in this manual when receiving fuel, at the airport storage facility and on all refueling apparatus.
 6. Maintaining appropriate up-to-date records as verification that all checks and tests have been performed. The record must be signed or initialed by the person performing the test or check. Upon request, such records must be made available for review to authorized persons from Piedmont Airlines and other authorized agencies. Records must indicate when fueling equipment is not in service.
 7. Assuring that all personnel are properly trained to perform their assigned duties safely and efficiently and to maintain appropriate records of said training. Documenting and maintaining form 4.2, "[Form P/FTF02, Piedmont Fueler Training Record](#)" for said training on file. Vendor (company) training forms are only authorized for use provided all the requirements from form 4.2, "[Form P/FTF02, Piedmont Fueler Training Record](#)" are accomplished, and the forms contain "Piedmont aircraft servicing" terminology. Initial and recurrent (annual) individual training (update) for Piedmont fueling procedures is a requirement. This can only be accomplished by a Piedmont Trainer, Piedmont QA auditor or the vendor's Designated Piedmont trainer.
 8. There shall be no deviation from the procedures prescribed herein without the expressed written consent from Piedmont Maintenance Personnel.
 9. A fuel vendor supervisor must be present in the event an abnormal refueling situation occurs, e.g., inoperative fuel gauge, requirement to transfer fuel, malfunctioning fuel valve, etc. Due to the infrequent occurrence of these situations and the exposure to mishandling, it is imperative that a fueling supervisor be present to oversee and coordinate the operation.
 10. The fueling vendor will ensure the equipment used to fuel piedmont aircraft is safe to operate prior to fueling piedmont aircraft. This shall be done by completing a general visual check of vehicle. This shall include but is not limited to lights, tires, brake system, ops check and related safety items that would impair the vehicle and its driver in operating the vehicle in a safety sensitive situation or the potential for a hazard to occur.
- C. The Quality Assurance representative is responsible for:
 1. Visiting each regular refueling station periodically (2 years) for the purpose of inspecting vendors' operations, procedures and facilities. Audits may be performed from information obtained from American, or their subsidiaries in lieu of an on-site audit, providing the information is current to within one year of request.
 2. Assisting fuel vendor and station personnel with questions and problems that arise regarding the fueling operation in general.
 3. Assisting fuel vendor and station personnel by investigating and reporting deficiencies in the fueling operation.
 4. Reporting unacceptable conditions to the proper departments, companies, and authorities, and assisting in coordinating the efforts to correct the situation with minimum disruption of operations.
 5. Assuring that fuel servicing personnel are properly trained and assisting, if necessary, by conducting or arranging the necessary training.
 6. Maintaining the vendor audit and training records.

1.3 Aircraft Fueling Procedures Manual Revisions/Upgrades

✎ Aircraft Fueling Procedures Manual program enhancements:

Piedmont Airlines' Fueling policies, procedures and training material constantly undergo development and improvement. The Manager of Quality Assurance shall determine needed changes to the Aircraft Fueling Procedures Manual (AFPM) based on Industry standards, Quality Assurance audit findings, FAA concerns, Safety Awareness, Enhancements, etc. Refer to the Technical Publications Manual (TPM) subsection 2.2.1, "Manual Revision Acceptance/ Approval Process" for policy and procedures on changes made to this manual which includes changes to the program.

1.4 Fuel Requirements

The Embraer 145 Aircraft have Turbine Engines. These engines require certain properties in their fuel. Very large quantities of fuel must burn in a restricted space at high pressures and heat release rates without forming deposits or sludge if exposed to high temperatures in the fuel lines leading to the burners or "combustors", and the fuel must not form corrosive products which will attack engine parts in the exhaust system. Furthermore, the fuel should not solidify at the very low temperatures experienced at high altitudes. On the other hand, turbine fuels have no octane requirement, nor must they be light enough to be evaporated in a fuel control unit.

Turbine fuels, therefore, are high quality fuels covering the general heavy gasoline and kerosene boiling range. They do not contain dyes or tetraethyl lead. They should have excellent storage stability and water separating characteristics.

They should always be handled in separate facilities to avoid contamination with other types of products. They must be kept extremely clean to avoid damage to sensitive aircraft fuel system parts. They must also be kept free of water which would freeze at high altitudes and plug the fuel system. Elimination of water is also essential to prevent the growth of microbiological organisms.

The Piedmont Fuelers manual is intended to provide guidance to the user covering the safe storage and distribution of quality jet fuel at airports as currently practiced in the commercial aviation industry. Due to the wide diversity of airport fueling operations, this document is not intended to be all-inclusive. Technical information, along with competent judgment, must be considered and followed at all times when overseeing aviation fueling operations. In addition, operators must comply with all applicable rules, regulations, restrictions, ordinances and other laws of federal, state, local and airport entities relating to fuel storage and distribution. Therefore, please reference current ATA SPEC 103 "Standards for Jet Fuel Quality at Airports" and the most current Piedmont Fuelers manual in addition to any other required guidance that must be used for Piedmont fueling operations.

1.5 Fuel Specifications

Turbine fuel specifications have been issued and used for years by the military services. Specification MIL-T-5624 covers the fuels designated by the JP-series. Those in general use include fuel identified as JP-4 and JP5.

For commercial use, the American Society for Testing Materials (ASTM) has specification D-1655 for fuel identified as Jet A/A-1 and Jet B fuel.

- A. Jet A/A-1 - Kerosene type fuels refined under ASTM D-1655. Similar in all properties except for their freezing levels.
 - Jet A freezes at -40 C (-40 F)
 - Jet A-1 freezes at -47 C (-53 F)
- B. . Jet B - Wide-cut fuel refined under ASTM D-1655. Very similar to Jet A/A-1; however, differs in volatility and fluidity.
 - Jet B freezes at -50 C (-58 F)

Switch Fueling

18 NOV 20

C. JP-4 - Wide-cut fuel refined for military use under specification MIL-T-5624. Very similar to Jet B fuel. Used primarily by the U.S. Air Force and Army since it meets their operational requirements and reflects a broad availability. Has a lower freeze point and a wider boiling range with the initial boiling point and specific gravity considerably below that of kerosene.

JP-4 freezes at -58 C (-72 F)

D. JP-5 - Kerosene type fuel refined under military specification MIL-T-5624. Used by the U.S. Navy primarily in its carrier operation due to its high flash point which offers safer handling characteristics on shipboard.

	Jet A/A-1	Jet B	JP-4	JP-5
Gravity, API (60 F) (15 C)	37 - 51	45 - 57	45 - 57	36 - 48
Relative Density (15.5 C)	0.751 - 0.840	0.751 - 0.802	0.751 - 0.802	0.788 - 0.845

1.6 Switch Fueling

Piedmont aircraft may be operated into airports which are not included in Piedmont's normal flight system. In certain instances, the primary fuels approved for use on Piedmont aircraft (Reference: "Approved Fuels") may not be available. In these cases, Maintenance Control must be contacted before any alternate approved fuel is dispensed into Piedmont aircraft.

Jet fuels are made up of hundreds of different hydrocarbons which are essentially non-conductors of electricity. The conductivity range varies between fuel types due to the different amounts of additives which increases the conductivity to a lesser or greater extent depending upon the chemical nature and the concentration of the impurities. In most cases, the conductivity will be very low. This low conductivity is the fundamental property that can cause a very hazardous situation to arise in handling flowing fuels. When fuel is flowing, it tends to become electrically charged which cannot be dissipated due to the low conductivity.

Mixing fuels of different specification in a common tank is capable of generating sufficient electrostatic energy to ignite fuel vapors, resulting in a fire.

When fuels are mixed, the following approved procedures must be strictly adhered to:

1. Refueling unit must be operated at 1/2 the normal flow rate.
2. Bonding procedures must be strictly adhered to.

1.7 Fueling Records

- Fuel records must be submitted do designated local American Airlines representative to be retained no less than 4 years. [MSC no longer exists, all the records are kept and entered by local AA/AE personnel]
- Completed Fuel Service Records ("FSRs" or "Fuel Slips") must include at least the following details for each fueling: Date of Fueling, Aircraft Tail Number, Flight Number, Gallons Added. Additional detail is encouraged but not required.

1.8 Overall Process Responsibility**A. Responsibility**

The Vice President of Maintenance and Engineering is responsible for this program, its processes, policies, and procedures.

The VP of maintenance must ensure financial and human resources for the safety and quality performance of this program are provided".

1. . Qualifications for the Vice President of Maintenance and Engineering are as follows:

The Vice President Maintenance and Engineering may be qualified through previous training, experience, and expertise. He must have a full understanding of the following materials with respect to Piedmont' operation:

Overall Process Responsibility

02 JUN 20

- a. Aviation safety standards and safe operating practices.
- b. Piedmont' Operations Specifications.
- c. All appropriate maintenance and airworthiness requirements from 14 CFR Parts 1, 5, 21, 23, 25, 43, 45, 47, 65, 91, and 121.

The Vice President of Maintenance and Engineering must hold an Airframe & Powerplant certificate.

The Vice President of Maintenance and Engineering will discharge his duties to meet applicable legal requirements and maintain safe operations.

B. Authority

The Quality Assurance Manager or his designee has the authority to establish and modify this program, its processes, policies, and procedures.

I. . Qualifications for the Quality Assurance Manager are as follows:

- a. . Must hold a valid Airframe & Powerplant certificate.
- b. Has had at least three years experience in the maintenance of large aircraft, one year of which must have been in a supervisory capacity.
- c. Know the appropriate parts of the Maintenance Policies and Procedures Manual, including applicable provisions of CFRs.

C. Controls

Controls are written into the manual system to ensure that manual policies, procedures, instructions and information are followed. Controls are identified throughout procedures by the  symbol.

D. Interfaces

Manual procedures interface with procedures in other sections, chapters and/or manuals. The individuals holding procedural authority for these interfaces are identified below. Prior to any change or revision to this manual, each procedure authority holder must assess the impact of changes to their respective procedures listed below and take appropriate action to ensure manual consistency. Refer to "Comment Report" on page Comment-i of Piedmont MPP.

Procedure Authority Holder	Interface
Director of Technical Support and Engineering	MPP Section 2.6.1 Organization Charts MPP Section 4.5.1 Quality Assurance Manager MPP Section 16.3.5 Fuel Provider Audits
Vice President, Safety and Regulatory Compliance	OMM Chapter 8 Safety Management System (SMS) SPPM Section A.6 IEP Form 6

E. Process Measurement

The IEP and CASS provide measurement and assessment of processes to identify and correct problems or potential problems and to make improvements to the Piedmont' Maintenance Program. All programs are audited via SPPM Appendix, B IEP. These audits were developed utilizing system safety data collection tools.

1.9 General Safety Rules

The following rules provide general requirements for safety during refueling/defueling of aircraft.

1.9.1 Rules

- A. The best way to fight a fire is to prevent it from starting.
- B. Observe all local fire laws, regulations, and procedures.
- C. Provide a fire guard with adequate extinguisher when hazardous conditions exist.
- D. In the event of a fire, immediately notify the flight crew, contact the local fire department and follow all local emergency response procedures
- E. Prohibit smoking, cell phone usage and open flames of any kind near fuel storage areas, fueling equipment, or in or near aircraft.
- F. Post "NO SMOKING" signs in cabs of fueling equipment. Remove lighters and ash trays from vehicles.
- G. Follow bonding procedures stated in this manual.
- H. Do not park fueling equipment under any part of the aircraft.
- I. Position aircraft allowing enough room between aircraft for emergency fire equipment to be driven.
- J. Always use a guide man when backing fuel truck directly towards the aircraft. Obstructed Vision- A person operating a vehicle transporting Combustible Materials may not move the vehicle in any direction in which his visions (or back-up camera view) is restricted in any manner unless and until a guide is positioned outside the vehicle to assist the operator. The fueler will be responsible for obtaining the guide man personnel when fuel trucks encounter this configuration. See AFPM 2.11 for additional back-up camera requirements.
- K. Do not perform any maintenance jobs which might ignite fuel vapors.
- L. Do not perform fueling operations if there is lightning detected within 3 miles of fueling location.
- M. Do not use automatic hold-open nozzles for refueling.
- N. Chock aircraft and fuel truck during fueling.
- O. Make sure refueling vehicle's emergency brake is set and engine stopped if not necessary for pumping operation.
- P. Drain aircraft's sumps as outlined in specific aircraft procedures. (if required)
- Q. Aircraft engines should be stopped prior to commencing fuel servicing, unless Alternate Refueling Procedures are being utilized.
- R. Never connect, disconnect or operate battery chargers during fueling operations.
- S. Position ground power unit as far as possible from fueling point; never under any part of the aircraft or within 5 feet of the trailing edge of the wing.
- T. If passengers remain on board during fueling operation, make sure "NO SMOKING" sign is on in the passenger cabin.
- U. Follow these restrictions where radar is operated:
 - Airport Surface Detection Radar - Do not fuel within 100 feet of radar equipment or antennas.
 - Ground Control Approach Radar - Do not fuel within 300 feet of radar equipment or antennas.
- V. Always use a flagstick or cone for pit identification during hydrant refueling.
- W. When passengers are allowed to remain on board the aircraft during refueling, a cabin attendant must be stationed in the cabin at, or near, the main entrance door. The main entrance door must be open at all times during refueling.
- X. Deadman control must be in the hands of the operator during refueling and never jammed or locked in the open position.
- Y. Adhere to all traffic rules and airport driving regulations.

General Safety Rules**30 JUL 24**

- Z. Never approach an aircraft for servicing faster than a normal walking pace.
- AA. Before approaching the aircraft, always check the security of your brakes.

Chapter 2: Safety

2.1	Purpose	2-1
2.2	Static Electricity	2-2
2.3	Bonding and Grounding Requirements	2-3
2.4	Over-wing Fueling	2-3
2.5	Lightning and Open Flames	2-4
2.6	Fuel Spills.....	2-4
2.6.1	General.....	2-4
2.6.2	+Fuel Spill Specific Handling Procedures	2-5
2.7	Fire Extinguishers	2-9
2.8	Fire Extinguisher Rules.....	2-9
2.9	Types of Fire Extinguishers.....	2-10
2.9.1	Carbon Dioxide Extinguishers	2-10
2.9.2	Dry Chemical Extinguisher	2-10
2.10	Fire Extinguishers Requirements	2-11
2.10.1	+ Aircraft Fueling/Defueling	2-11
2.10.2	Service Water Separators	2-11
2.10.3	Loading Fuel Trucks.....	2-11
2.10.4	Repairing or Servicing Fuel Storage or Distribution Systems	2-11
2.11	Back-Up Camera Policy	2-12
2.11.1	Minimum Requirements:	2-12
2.11.2	Training and Documentation	2-12

Chapter 2: Safety

2.1 Purpose

American Eagle places the highest possible priority on instituting and maintaining fuel handling and servicing procedures which will assure the highest degree of safety

Aircraft fuel servicing involves the transfer of large quantities of highly flammable liquid under conditions that are far from ideal from a safety standpoint.

Operational requirements make it necessary for fueling crews to perform their duties efficiently and quickly under all types of weather conditions, and at all hours and at the same time as a number of other aircraft servicing operations are being performed.

The increasing fuel capacities of modern aircraft and bulk storage facilities aggravate the problem and make it imperative to establish basic safety procedures.

The following text is provided to familiarize you with terminology utilized to describe the volatility of aircraft fuel.

Flash Point - Flash point of a fuel is the temperature at which the liquid gives off vapors that can ignite.

This temperature is:

Below 0° F. for gasoline and JP4

Above 100° F. for kerosene

Ignition Temperature - Ignition temperature of a fuel is the temperature to which the fuel must be heated for it to ignite and continue to burn. This means for flammable liquid vapors, the lowest temperature for an ignition source to ignite the vapor is the ignition temperature.

This temperature is:

Below 500° F. for kerosene & JP4

Near 1000° F. for gasoline

Flammable Limit - This is the percentage of fuel vapor mixed with air that burns. This limit is about 1% or 7% for petroleum fuels.

Kerosene has the safety advantage, but a spill on a very hot ramp could reach its flash point temperature.

One very important factor remains. Any fuel is readily capable of igniting when in a fine spray. This possibility always exists with a small pinhole in a fueling hose. The area around the hole creates a fuel mist and is hazardous at any temperature.

When we think of safety in fuel handling, we must bear in mind the purpose of fuel. It is intended to burn under controlled conditions, within the combustion area of an engine. The greatest hazard in handling fuel is fire. To start a fire there are three essential elements: fuel, air and ignition. Air surrounds us; we are working with a fuel; the only missing element is ignition. The three most common sources of ignition are: static electricity, lightning, and open flames.

Static Electricity

13 MAR 19

2.2 Static Electricity

Static electricity is a constant threat to safe fueling. A charge of static electricity is nearly always produced when two dissimilar materials make physical contact and then are separated. An example of this is when you scuff your shoes across a heavily carpeted floor. A static charge is built up in your body by the shoes making and breaking contact with the carpet. It is usually discharged harmlessly as a spark from the fingers just before they touch some metal object such as a door knob.

The presence of static electricity is not easily apparent until a discharge of spark occurs. This increases the danger during fueling. Static electricity can be generated by fuel flowing through the hose or even by fuel falling into a barrel. It accumulates on an aircraft during flight or on the ground. Particles of rain or snow, or ice crystals or dust blowing across the aircraft can produce a very heavy charge of static electricity. The servicing truck, like any rubber-tired vehicle, may become electrified. Static can also be collected by induction from electrically-charged atmosphere.

Static is always present day or night, in wet or dry weather. It is more dangerous in dry weather because dry air is a non-conductor and permits higher voltage to build up before discharging. Sparks do not have to be visible to cause disaster. About 20,000 volts are required to produce a 1-inch spark; a human has been known to build up as much as 10,000 volts walking across a living room carpet.

Heavy fuel and oil trucks could build up as much as 40,000 volts as a result of the fuel sloshing about in the tank and by air passing over the truck. In this same manner, a static charge is built up in an airplane. Fuel trucks are usually equipped with a graphite strap dangling on the ground to discharge static as it builds up, and so prevent such high charges. This strap, however, must not be considered an adequate ground. Refer to NFPA 407 standards in the appropriate Chapter 6 or 7.

Static electricity flows along the path of least resistance, just as lightning follows the highly conductive copper lightning rod and cable into the ground. If no easy path is provided, the charge builds up. When the charge is great enough, or when the distance to the point of lower potential or to the ground is sufficiently reduced (as when the fingers approach a door knob or the hose nozzle nears the wing) the charge jumps the gap as a spark. Under favorable conditions, this spark is capable of igniting flammable vapors as is the discharge across the points of a spark plug.

In order for static electricity to cause a fire, it is necessary for these conditions to exist at the same time and place:

- The Static Charge Must have sufficient energy to create a spark
- There must be a gap for the spark to jump across.
- The spark must occur in a mixture of fuel vapor and air that is within the flammable range.

It is impossible to prevent the presence of flammable vapors in the areas adjacent to the fuel tank filler openings. Therefore, it is essential that the static that accumulates on the aircraft and the truck are not permitted to discharge as a spark. This can be accomplished by "bonding" the truck and the hose nozzle to the aircraft.

Proper bonding will equalize the potentials. If accomplished, no spark will result. These procedures establish the bonding required during a fueling operation. Refer to NFPA 407 standards in the appropriate Chapter 6 or 7.

• **Note** •

Do not wear nylon or synthetic clothing which may generate static electricity

Bonding and Grounding Requirements

13 MAR 19

2.3 Bonding and Grounding Requirements

☞ All bonding equipment must meet these requirements:

- Cables must be bare or covered with a molded plastic and sufficient gauge to hold up under mechanical strains and use. A good conductor for our use is 3/16" stranded copper cable.
- Plug and jack assemblies and spring clamps must be unpainted metal and clips sturdily constructed.
- Bond fueling vehicle to aircraft.
- Attach static bonding clamps to the approved bonding point on the aircraft. Do not attach clamps to other surfaces on the gear or wing as this could cause scratches and gouges on high strength steel parts.
- Radar equipment must be OFF during refueling. Do not make repairs to or remove equipment from electrical circuits that are being powered during refueling.
- Do not operate switches which control units in the wing or tank areas during refueling except in emergency. (Switches required in the refueling operation may be opened or closed as required.)
- Use graphite straps as drag units on fuel trucks when required. DO NOT use chains or other material which produces sparks.
- Keep bonding cable connections clean. Do not allow clips, plugs, and grounding posts to become corroded or covered with paint. Ensure that a good connection is achieved. Use only nonferrous metals for these connectors.
- Bonding system (cables, reels and clips) must be inspected for continuity and integrity monthly.

2.4 Over-wing Fueling

Always bond the nozzle to the aircraft before opening the tank filler cap. The nozzle must remain bonded to the aircraft until after the tank cap has been replaced.

On aircraft not equipped with wing grounding jacks, attach the bonding clip to a projection in the filler well, not to the access door. Make this connection before the filler cap is opened.

Disconnect static ground wires in reverse order when refueling/defueling is completed.

Place a protective pad or mat around the fuel filler opening. When inserting or removing the fuel nozzle, use extreme care to prevent the fuel hose from rubbing against the deicer boot. Also, do not allow fuel to contact the deicer boot.

Lightning and Open Flames

18 NOV 20

2.5 Lightning and Open Flames

☞ Observe the following during fueling operations:

- A. Lightning is static electricity of tremendous potential. To safeguard against lightning is extremely difficult; therefore, when thunderstorm activity is forecast, local management should follow the storm center location, velocity, and direction.
- B. Fueling vendor procedure: FUELING OPERATIONS SHOULD BE SUSPENDED WHEN LIGHTNING IS WITHIN THREE MILES OF FUELING LOCATION. Additionally, always follow local AOA and fuel vendors requirements when lightning is present.
- C. Fuel vapors are heavier than air and under calm wind conditions may collect in depressions surrounding the ramp area. Therefore, fueling operations should not be performed if any of the following items are within 50 feet of the aircraft:
 1. Kerosene or gasoline flame heaters
 2. Welding or cutting torch operations
 3. Flare pots
- D. Matches and cigarette lighters should not be carried by personnel engaged in fueling operations and smoking regulations must be strictly adhered to.
- E. Cell phones may not be used during fueling operations or in the vicinity of fueling equipment or storage areas.

2.6 Fuel Spills**2.6.1 General**

One of the most serious hazards in our ground operations is fire from aircraft fuel spills. We can minimize the number of accidental spills by:

- Careful operation of fuel servicing equipment
- Proper training of personnel
- Proper maintenance of equipment

The following general precautions must be taken for all fuel spills:

- Immediately stop the flow of fuel.
- Notify the Fire Department if the fuel spill exceeds 10 feet in diameter. Position personnel with a fire extinguisher until the Fire Department arrives.
- Have anyone sprayed or covered with fuel remove fuel-soaked clothing and wash immediately.
- Do not allow anyone to walk through the fuel spill area.
- Move mobile vehicles or leave "as is." No set rule can be fixed as shutting down equipment may ignite the spilled fuel.
- Use caution when starting or stopping any engine.
- Move fuel servicing vehicles away from the area only after the hose has been stowed away.
- If any aircraft has engines running, move it away from the area UNLESS the air currents from the moving aircraft would aggravate the vapors of the spilled fuel.
- DO NOT allow the fuel to be washed down sewers, drains or manholes, unless it is the decision of the Fire Department. Do not allow operations which might ignite vapors in the area until you are sure that all vapors

Fuel Spills

13 MAR 19

have evaporated.

- If jet fuel is spilled, use an emulsion compound on the area then wash with water, if required.
- Allow any cargo or baggage that has been soaked with fuel to set in an open area for at least six hours before placing aboard an aircraft.
- The FBO contract/capability and the airport authority policy for fuel handling varies from station to station. It is critical that you know what AA's responsibility is at your station.

2.6.2 Fuel Spill Specific Handling Procedures

WHODOES WHAT

A. Fueler

1. Notifies any available American or American Eagle Customer Service Agent or, in their absence notify, any available American or American Eagle employee.

• Note •

Cockpit Crew and/or Flight Attendants must be immediately notified and passengers must be deplaned when:

- a. The fuel spill ignites.
- b. The flow of fuel cannot be stopped.
- c. The condition of the spill is such that fire is imminent or probable.

Caution

Regardless of whether the communication is to the cockpit crew or the flight attendant, the word "evacuate" should never be used. It could easily be interpreted to be a full-scale evacuation using all available exits. (Rear Emergency Exits may cause passengers to inadvertently enter the fuel spill area)

Use the word "deplane" to convey the message that the airplane is to be vacated.

2. Reports each fuel spill to his supervisor.

Fuel Spills

13 MAR 19

WHO

B. American Eagle
Customer Service
Agent

DOES WHAT

1. Evaluates situation
2. Determines if it is necessary to deplane passengers.

• Note •

Cockpit Crew and/or Flight Attendants must be immediately notified and passengers must be deplaned when:

- d.* The fuel spill ignites.
- e.* The flow of fuel cannot be stopped.
- f.* The condition of the spill is such that fire is imminent or probable.

Caution

Regardless of whether the communication is to the cockpit crew or the flight attendant, the word “evacuate” should never be used. It could easily be interpreted to be a full-scale evacuation using all available exits.

Use the word “deplane” to convey the message that the airplane is to be vacated.

3. Notifies Cockpit Crew (or in their absence, the Flight Attendant) of the situation.
4. Ascertains additional action required (e.g. notification of Fire Department if situation warrants same, BUT in all cases if the fuel spill exceeds 10 ft in diameter).
5. Verifies that spill is removed and it is safe to resume operation.
6. Completes appropriate fuel spill reports (if required).
7. Investigates cause of spill and takes action to prevent recurrence in the future.

Fuel Spills

13 MAR 19

WHOB. American Customer
Service Agent**DOES WHAT**

1. Evaluates situation
2. Determines if it is necessary to deplane passengers.

• Note •

Cockpit Crew and/or Flight Attendants must be immediately notified and passengers must be deplaned when:

- g.* The fuel spill ignites.
- h.* The flow of fuel cannot be stopped.
- i.* The condition of the spill is such that fire is imminent.

Caution

Regardless of whether the communication is to the cockpit crew or the flight attendant, the word “evacuate” should never be used. It could easily be interpreted to be a full-scale evacuation using all available exits.

Use the word “deplane” to convey the message that the airplane is to be vacated.

3. Notifies Cockpit Crew (or in their absence, the Flight Attendant) of the situation.
4. Ascertains additional action required (e.g. notification of Fire Department if situation warrants same, BUT in all cases if the fuel spill exceeds 10 ft in diameter).
5. Verifies that spill is removed and it is safe to resume operation.
6. Completes appropriate fuel spill reports (if required).
7. Investigates cause of spill and takes action to prevent recurrence in the future.

Fuel Spills

13 MAR 19

WHO

C. American Mechanic

DOES WHAT

1. Evaluates situation
2. Determines if it is necessary to deplane passengers.

• Note •

Cockpit Crew and/or Flight Attendants must be immediately notified and passengers must be deplaned when:

- j.* The fuel spill ignites.
- k.* The flow of fuel cannot be stopped.
- l.* The condition of the spill is such that fire is imminent or probable.

Caution

Regardless of whether the communication is to the cockpit crew or the flight attendant, the word “evacuate” should never be used. It could easily be interpreted to be a full-scale evacuation using all available exits.

Use the word “deplane” to convey the message that the airplane is to be vacated.

3. Notifies Cockpit Crew (or in their absence, the Flight Attendant) of the situation.
4. Notifies supervisor and advises of action taken. If unavailable, completes steps 5 & 6, below.
5. Ascertains additional action required (e.g. notification of Fire Department if situation warrants same, BUT in all cases if the fuel spill exceeds 10 ft in diameter).
6. Verifies that spill is removed and it is safe to resume operation.

Fire Extinguishers13 MAR 19

2.7 Fire Extinguishers*A. General*

The use of a portable fire extinguisher during the early stage of a fire may prevent spreading of the fire. The following basic principles are applicable to portable fire extinguishers.

- Keep the most appropriate type of extinguisher available.
- Inspect extinguishers on schedule. Recharge extinguishers immediately after use.
- Train personnel to use extinguishers properly and effectively.

2.8 Fire Extinguisher Rules

Keep a fire extinguisher available for emergency use. It should be a carbon dioxide or dry chemical type fire extinguisher.

- A. Check seals on the fire bottles each morning.*
- B. If the seal has been broken, weigh bottle to see if it has been discharged.*
- C. If it has been discharged, replace with a charged bottle.*
- D. If it has not been discharged, replace seal.*

• Note •

Each carbon dioxide bottle must be hydrostatically tested every 5 years. The date the test was last performed is stamped on the neck of the bottle. Add 5 years to this date to determine when the next test is due. Contact your vendor to perform this test.

Types of Fire Extinguishers13 MAR 19

2.9 Types of Fire Extinguishers**2.9.1 Carbon Dioxide Extinguishers**

The carbon dioxide extinguisher contains liquefied carbon dioxide which:

- is under approximately 850 pounds pressure.
- turns into a fire-smothering vapor or snow.
- must be operated at close range (6 to 10 feet).
- discharges quickly.
- must be operated with wind at user's back.
- dissipates quickly in high winds (reducing effectiveness).
- leaves no residue

Use the carbon dioxide extinguisher on aviation fuel, oil, grease and other flammable liquids, and electrical fires. Watch for possible flash-back.

WARNING

Do not use carbon dioxide extinguisher on brake fires.

2.9.2 Dry Chemical Extinguisher

The dry chemical extinguisher is considered the best all-around unit for normal airline ramp operations. The extinguisher contains a pressure container or carbon dioxide or nitrogen and a charge of dry chemical, sodium bicarbonate which:

- turns into a fire-smothering powder.
- operates at a range of 8 to 12 feet.
- does not dissipate as easily as CO₂ in wind.

Use the dry chemical extinguisher on flammable liquids, electrical and brake fires.

• Note •

Bottles installed vertically on vehicles should be removed from rack and inverted (fluffed) approximately every 30 days to keep powder from compacting

Fire Extinguishers Requirements13 MAR 19

2.10 Fire Extinguishers Requirements

The following lists the fire extinguisher requirements necessary for protection of fueling equipment and fuel servicing operations:

2.10.1  Aircraft Fueling/Defueling

- A. Maintain at least one dry chemical/carbon dioxide extinguisher at the ramp during any aircraft fueling operation.
- B. Paint lines indicating locations for extinguishers on the ramp, behind the equipment line. Access to extinguishers must be kept clear so that they will be readily available in an emergency.
- C. Do not wheel extinguishers out to the aircraft for routine fueling. If an unusual condition exists that would hinder ready access in an emergency, reposition the extinguishers in separate locations upwind of the aircraft and remote from probable hazardous areas before the fuel servicing operation begins.

2.10.2 Service Water Separators

Have at least one dry chemical/carbon dioxide extinguisher available whenever a water separator is drained and filter elements in filter-water separator units are changed.

2.10.3 Loading Fuel Trucks

Keep at least one dry chemical/carbon dioxide extinguisher available at the truck loading area. Mount the extinguisher in a fixed position (fence, post, etc.) at least 25 feet and not beyond 50 feet from the loading rack.

2.10.4 Repairing or Servicing Fuel Storage or Distribution Systems

Keep at least one dry chemical/carbon dioxide extinguisher immediately available whenever repairs are made to a fuel storage or distribution system. If extensive repairs are planned, at least one wheeled dry chemical extinguisher is recommended.

Back-Up Camera Policy

30 SEP 24

2.11 Back-Up Camera Policy

Piedmont Airlines understands that back-up cameras have become common place. Back-up cameras are used throughout all industries as well as in our daily commutes. Fueling is not an exception. There is a risk of us becoming desensitized to their use. Due to the critical and possibly catastrophic nature of aircraft fueling, Piedmont Airlines has adopted the following minimum standards. These standards are meant to provide a guideline as to what Piedmont Airlines expects when a back-up camera is used in place of a guide person during fueling operations. If any of the following requirements are not met, a guide person shall be present when backing up near an aircraft.

At any time, Piedmont Airlines reserves the right to suspend the use of back-up cameras at any location/agency. This may be due to history, incidents, or any other extenuating circumstance. Written notice will be provided and documented by the Manager of Quality Assurance or Designee.

2.11.1 Minimum Requirements

1. At no time shall a back-up camera be used to back directly towards an aircraft. In the event this is inevitable, a guide person shall be used.
2. At no time shall a truck back-up within 5 feet of an aircraft without the assistance of a guide person. This 5-foot distance excludes mirrors or other protruding distance markers.
3. Cameras shall be equipped with wide angle lenses.
4. Prior to placing the truck in reverse, a thorough walk-around inspection shall be performed to identify and address any potential hazards.
5. The fueler must ensure that wingtip cones are correctly positioned within the designated operational area, including areas where other aircraft may be present.
6. Wingtip and wingtip cones, of all aircraft in the operational area, must remain clearly visible to the fueler throughout the entire process of backing away from the aircraft.
7. Fueler shall perform routine checks to ensure the cleanliness and proper functioning of the back-up cameras, as well as the functionality of any back-up sensors.
8. Fuelers shall refrain from using unauthorized earpieces that could impede oral notifications.
9. Back-up lights as well as aural warning devices, if installed by the manufacturer, shall be routinely verified for operation.

2.11.2 Training and Documentation**1. Training**

- a. The fueling agency must provide documented comprehensive initial training and Physical OJT (on-the-job training) for the utilization of the back-up camera.
- b. Training may be recurrent or non-recurrent based on the fueling agency's internal assessment.
- c. The training must be performed by a previously qualified fueling agency/truck manufacturer employee, supervisor, lead or designee.

2. Documentation

- a. Fueling agency's back-up camera use policies shall take precedence over this chapter but no policies shall contradict or be of lower standards.
- b. In the event a fueling agency does not have written procedures for the use of back-up cameras, this chapter shall be used.
- c. Training shall be performed and documented using the fueling agency's internal procedures and forms.
- d. OJT and/or evaluation forms shall be retained until the training and/or evaluations are superseded, or the employee is no longer employed by the fueling agency.
- e. No retention of records is necessary once the employee is no longer employed by the fueling agency.
- f. Prior to using back-up cameras before, during or after fueling, the hired/rehire employee back-up camera use training shall be documented/verified by previously completed training records or performing/documents new training.
- g. No grandfather clauses will be accepted. All employee training shall be documented.

Chapter 3: ATA 103 and Definitions

3.1 Terms and Definitions 3-1

Chapter 3: ATA 103 and Definitions

• Note •

☞ Piedmont utilizes the most current revision of ATA 103 as its standard for US based fueling vendors. Piedmont's US Based vendors will be required to maintain a copy of the most current revision of ATA 103. ATA 103 and the Piedmont Aircraft Fueling Procedures Manual are the documents to which Piedmont's fueling vendors will be audited.

If there is an area or areas of ATA 103 with which the vendor is not able to comply, or the vendor is based outside of the US and follows a fuel standard of equal quality, a waiver must be requested by the vendor.

3.1 Terms and Definitions

Various terms peculiar to the handling of aviation jet fuel appear in this manual. As used herein:

Additives Compounds used to impart new properties to a product or to improve a property which it already possesses.

Adsorption A separation method where a component of a mixture is concentrated on a surface e.g.: Surfactants (surface-active-agents) are separated from jet fuel by adsorption on clay.

API (American Petroleum Institute) The institute represents and is supported by the petroleum industry. It standardizes the tools and equipment used by the industry and promotes the advancement of research in the petroleum field.

API Gravity An arbitrary scale expressing the density of liquid petroleum products, as established by the American Petroleum Institute (API). The measuring scale is expressed in terms of degrees API from 0 to 100, the higher the API gravity, the lighter the compound. API gravity can be reported at observed temperature or corrected to 60°F. (See Relative Density.)

Ambient Temperature The air temperature at a specific location

Antioxidant A chemical added to petroleum products to inhibit oxidation.

Appearance Refers to the visual examination of fuel; appearances are, clear, bright, hazy, and cloudy

ASTM (American Society of Testing and Materials) A scientific and technical organization formed for the development of standards on characteristics and performance of materials, products, systems, and services and the promotion of related knowledge.

Barge A vessel, either motorized or towed, used to carry products in navigable waterways.

Barrel (bbl.) A common unit of measurement of liquids in the petroleum industry. It equals 42 US standard gallons.

Batch A measured amount in which crude oil and refined product shipments are sent through a pipeline.

Batching Sequence The order in which shipments are sent through a pipeline.

Blending The procedures by which pre-determined quantities of two or more similar products are homogeneously mixed to upgrade one of the products or to produce an intermediate grade or quality. This term is also used to define the injection of additives, such as corrosion or icing inhibitors, into fuels.

Breathing The movement of gas (product vapors or air) in and out of the vent lines of storage tanks.

Calibration (1) The graduation of a measuring instrument. (2) The determination of accuracy of graduation in a measuring instrument.

Terms and Definitions

13 MAR 19

Cathodic Protection An electrolytic method of protecting a buried pipeline or other metal structure against corrosion by surrounding it with an electrical field strong enough to overpower the currents seeking to leave the metal to go into the soil. (See Impressed Current and Sacrificial Anode)

Clay Treatment Vessel A vessel containing bulk clay, clay bags or clay canisters used for removing surfactants (surface-active-agents), by adsorption, from jet fuel.

Clear and Bright Clear is the absence of visible solids, a cloud, a haze, an emulsion, or free water in the product. Bright is the sparkle of clean, dry product in transmitted light.

Coalescing (1) Drawing together, combining, or uniting to form one body. (2) A method of separating finely divided or suspended water from a petroleum product by passing the product through filter media of a filter/separator.

Coalescer Element The first stage cartridge in a filter/separator vessel that removes solid particles and coalesces free water from jet fuel. It is upstream of the separator cartridge.

Commingling The mixing of two or more products of different ownership, type, or grade.

Conductivity The ability of a given substance to conduct electric current.

Contaminants Substances which may be present in jet fuel that detract from its performance.

Contaminated Product A product in which one or more grades or types of products have been inadvertently mixed; or a product containing contaminants such as dust, dirt, rust or water.

Copper Strip Corrosion Test A qualitative method of determining the degree of corrosivity of a fuel by suspending or placing a strip of polished copper in a sample of fuel and comparing the test strip with a standard.

Correction Factor Due to the natural effects of thermal expansion and contraction of petroleum products in general, petroleum products must be corrected to a volume at 60°F for inventory and/or quality control purposes. Petroleum products are temperature corrected by using API Tables 5B and 6B for Generalized Products. Table 5B is for Correction of Observed API Gravity to API Gravity at 60°F. Table 6B is for Generalized Products, Correction of volume at 60°F against API Gravity at 60°F. Reference [[ASTM D1250](#)].

Deadman Control A control device which must be hand held by the operator to allow fuel to flow. When released, fuel flow stops automatically.

Dedicated System A system of pipeline(s), vessel(s), tank(s) and/or truck(s) used solely for the transportation and storage of one type of product.

Density Specific weight or mass of a substance per unit volume (pounds per cubic foot or gallon, or kilograms per cubic meter).

Differential Pressure (Delta P) The measured difference in pressure between any two points, generally between inlet and outlet connections on filtration vessels.

Dike An embankment or wall erected around a storage tank to contain the product if tank leakage or rupture should occur.

Direct Reading Differential Pressure Gauge A pressure gauge which automatically displays the differential pressure between the inlet and outlet connections of filtration vessels.

Disarming Action The process by which elements in filtration systems are rendered incapable of performing their designed functions.

Dissolved Water Water which is in solution in jet fuel. This water is not free water and cannot be removed by conventional means.

Effluent Stream of fluid at the outlet of filtration vessels.

Elements A generic term given to different types of decontamination media installed in various types of filtration vessels.

Terms and Definitions

13 MAR 19

Emulsion A dispersion of immiscible liquids in a continuous liquid phase.

Entrained Water Entrained water is found in fuels in the form of very small droplets, fog, or mist and it may or may not be visible. When large quantities of entrained water are present, the fuel will have a hazy or milky appearance. Water usually becomes entrained in the fuel when it is broken up into small droplets and thoroughly mixed with the fuel in equipment such as pumps or meters. Given sufficient time and the proper conditions, entrained water will settle out, however since turbine engine fuel is fairly dense it will hold entrained water in suspension for long periods of time.

Evaporation The conversion of a liquid into vapor, usually by means of heat.

Filter A device to remove solid particles from fuel.

Filter Membrane (Millipore®) Test A standard test in which jet fuel is passed through a small filter membrane. The cleanliness of the fuel can be determined by measuring the residue or amount of solid contaminants left on the membrane. (Ref. [ASTM D2276])

Filter/Separator A filtration vessel which removes solids and coalesces free water from jet fuel. Filter/separators are equipped with two or more types of cartridges, including coalescer elements (first stage) and separator elements (second stage).

Fixed Base Operator (FBO) Common title for aircraft fueling agents or vendors at airports.

Flash Point The lowest fuel temperature at which the vapor above the fuel will ignite. (Ref. [ASTM D56] or [ASTM D3828])

Floating Suction Pump suction piping with floatation capability used to draw the cleanest product from an upper level of the fuel in a jet fuel storage tank.

Free Water Water in fuel other than dissolved water. Free water may be in the form of droplets or haze suspended in fuel (entrained water or an emulsion) and/or water layered at the bottom of the container holding the fuel.

Freeze Point The fuel temperature at which the last fuel wax crystals disappear when the fuel is warmed. (Ref. [ASTM D2386])

Fuel System Icing Inhibitor (FSII) An anti-icing additive for jet turbine engine fuels.

Fungible Interchangeability of like product batches which can be substituted for purposes of shipment or storage.

Gallon (gal) A unit of measure of volume. A U.S. gallon contains 231 cubic inches or 3.78541 liters.

Gauging To measure the contents of a tank.

Gauging Table Tank specific measurement tables used to determine the volume of the tank at selected incremental levels.

Hydrometer A graduated instrument for determining the unit density of liquids. It is usually made of hollow glass and weighted at one end so as to float upright. The depth to which the instrument sinks when immersed in a liquid is determined by the density of that liquid. The lighter the liquid, the lower the instrument sinks. Some hydrometers are marked to read in degrees of API gravity, specific gravity (relative density), or density.

Hydrophilic Attracts water or is water wetting. Has an affinity for water. Opposite of hydrophobic.

Hydrophobic Repels water or is non-water wetting. Resists attracting water. Opposite of hydrophilic.

Immiscible Liquids which are mutually insoluble; Opposite of miscible.

Impressed Current Cathodic protection system utilizing a direct supply of electrical current to develop the potential difference between the (Energized) anode and the structure being protected. The method involves putting electrical current into the soil so that it flows toward and into the line or structure.

Influent Stream of fluid at the inlet of filtration vessels.

Terms and Definitions

13 MAR 19

Innage The volume of the liquid in a tank or container measured from the bottom of the tank to the top surface of the liquid.

Interface The common boundary (or surface) of two liquids.

Jet A/A-1 Fuel High-quality kerosene products used primarily as fuel for commercial jet and turboprop aircraft engines.

Joint Use Fueling Systems A fuel system shared by multiple users.

Liter (L) A metric unit of volume equal to 0.264 US gallons.

Lubricity The ability to lubricate. In fuels, it refers to a value that is measured by the BOCLE test. (Ref. [ASTM D5001])

Manifold A piping arrangement which permits a stream of liquid or gas to be divided into two or more streams, or which permits several streams to be collected into one.

Micron A metric unit of linear measurement; One micron is equal to 0.000039 inches and approximately 25,400 microns equals one inch.

Micronic Filter A filtration vessel or element designed to remove solid particles from aviation fuels.

Miscible Liquids which are mutually soluble; opposite of immiscible.

Monitor Element A cartridge designed to absorb water and remove particulates in aviation fuel. As the cartridge approaches its maximum capacity, flow is progressively restricted due to the accumulation of absorbed water and/or retained particulate matter.

NIST National Institute of Standards and Technology.

NFPA National Fire Protection Association.

Must Indicates a mandatory requirement.

Off-Specification Product A product which fails to meet one or more of the physical, chemical, or performance requirements of the product specification or is otherwise unfit for its intended use.

Ohm A unit of measure of electrical resistance; the higher the value, the greater the resistance to electrical flow.

Outage (or Ullage) The volumetric difference between the nominal capacity and the actual contents of a storage container.

Oxidation A chemical reaction whereby material(s) combine with oxygen to form a new compound.

Particulates Solid contaminants found in jet fuel, i.e., dirt, rust, sand or fibers.

Pipeline Batch The quantity of a product pumped into the pipeline in one continuous operation.

Pipeline Tender A quantity of product offered or designated for pipeline shipment moved in one or more batches.

Pre-Check System A system used to check the operation of the automatic high level shutoff equipment on tank trucks for preventing fuel spills.

Pressure Drop See Differential Pressure.

Product Unless indicated otherwise, jet fuel.

PSI Pounds per square inch; a measurement of pressure.

PSIG Pounds per square inch gauge.

Reclaimed Fuel: Fuel which has been removed from a fueling system (non-aircraft) for purposes of quality control checks or maintenance, which has been determined acceptable for return to storage.

Terms and Definitions

13 MAR 19

Relative Density The ratio of weight of any volume of fuel to the weight of an equal volume of water at the same temperature and pressure; sometimes referred to as Specific Gravity. Typically, the measurement is corrected to 60 degrees Fahrenheit.

Repeatability The allowable difference between two test results on the same sample by the same operator using the same equipment.

Reproducibility The allowable difference between two test results on the same sample by different operators in different locations.

Sacrificial (Galvanic) Anode Cathodic protection system utilizing a controlled cell, which shifts the corrosion on the protected structure to the sacrificial anode. Sacrificial anodes are consumed, but are installed so they are easily replaceable. Sacrificial anodes are commonly made of magnesium, aluminum, zinc, etc.

Sample A representative portion of fuel taken from a batch, tank or system etc., for analysis. Samples may be taken either manually or automatically.

Screen A filter, sieve, or barrier made of meshed wire or perforated metal intended to remove solid matter from a flow stream or to segregate particulates by size of solid matter.

Sediment Solid matter that settles to the bottom of a liquid filled container.

Separator Element The second stage cartridge or shroud in a filter/separator vessel that allows passage of jet fuel but repels free water. It is located downstream of the coalescer cartridge.

Settling Time The elapsed time that a product remains undisturbed between receipt of product into a storage tank before being discharged.

Shall Indicates a mandatory requirement.

Shelf Life The length of time a product, other than jet fuel, may typically be stored from the date of manufacture without deteriorating.

Should Indicates a recommendation or that which is advised, but not mandatory.

Sludge A deposit consisting of water, dirt, and other sediment.

Soluble Capable of dissolving or passing into solution.

Specification Prescribed limits of control used to maintain uniformity of a product.

Specific Gravity See relative density.

Sump (noun) A chamber or depression installed at the low point of fuel system components; such as storage tanks, filtration vessels, etc., to facilitate the collection and removal of contaminants.

Sump (verb) The process of removing liquid from a drain for the purpose of quality control.

Sumped Fuel: Fuel removed from sumps, e.g., storage tanks, filtration vessels, aircraft refuelers, etc., while performing routine quality control checks and equipment maintenance. Some sumped fuel may be recoverable. See Reclaimed Fuel.

Surfactants An acronym for surface-active-agents, which are chemical substances or detergent-like compounds frequently found in jet fuels. These chemicals reduce interfacial tension and may disarm the water removing capability of coalescer cartridges in filter/separators. Clay treatment is the primary means of removing surfactants from jet fuel.

Surge Tanks Small tanks that collect fuel from pressure relief valves and/or air eliminators.

Suspension Dispersion of small particles of a solid, or small droplets of a liquid, in a liquid or gas.

Switch Loading The loading of a high static charge retaining hydrocarbon (diesel, jet fuel, kerosene) into a tank truck, tank car or other vessel that has previously contained a low flash point hydrocarbon (gasoline Jet B, JP 4) and may contain a flammable mixture of product vapor and air.

Terms and Definitions

13 MAR 19

Temperature Degree of heat or cold as measured by a thermometer: Temperature centigrade degrees (C) is measured on a scale on which water freezes at 0 degrees and boils at 100 degrees. Temperature Fahrenheit (F) is measured on a scale on which water freezes at 32 degrees and boils at 212 degrees.

Thermal Stability The quality of a product to resist changes caused by heat such as oxidation or polymerization. Thermal stability measurements are related to the amount of deposits formed in the engine fuel system upon heating the fuel in a jet aircraft.

Thermohydrometer A hydrometer used in determining fuel density which has a built in thermometer for simultaneously measuring fuel temperature.

Thief (Sump) Pump A small pump having a suction line which extends to the low point of a fuel storage tank for the purpose of drawing off water, which may have accumulated.

Tolerance An allowable variance from a specified limit.

Trace An amount large enough to be detected, but not to be measured.

Turbine Fuel A generic term used for various kerosene-based fuels manufactured for use in jet engines.

Vapor Pressure The measure of the pressure exerted by a product in vapor form on the interior of a container.

Vendor An agent that provides services or products.

Vent An opening in a tank, container or pipe that permits the flow of air and vapor due to changes in pressure.

Waste Fuel Fuel that can no longer be used for its intended purpose.

Water Defense System A system or device, which detects excess free water in fuel systems and automatically stops the flow of fuel or sets off an alarm to prevent downstream contamination.

Water Finding Paste A paste which changes color on contact with water.

Water Slug A large amount of free water.

Working Tank The fuel storage tank being used to supply fuel to aircraft refuelers, refueling trucks or hydrant systems.

Chapter 4: Training and Waiver Procedures

4.1	Fueler Training and Documentation	4-1
4.1.1	Fuel Designated Trainer Training.....	4-1
4.1.2	Contract Fueling Personnel Training.....	4-3
4.2	Form P/FTF02, Piedmont Fueler Training Record	4-4
4.3	Form FVWR, Fuel Vendor Waiver Request	4-5
4.4	Form FVGW, Fueling Vendor Grant of Waiver	4-6
4.5	Form FuelVendor001, Piedmont Airlines Fuel Designated Trainer Account Request Form	4-7
4.6	Communications.....	4-8

Chapter 4: Training and Waiver Procedures

4.1 Fueler Training and Documentation

This subsection addresses Piedmont Airlines provided training to contracted Fuel Provider(s). Piedmont Airlines will provide initial and recurrent training in accordance with the Piedmont Airlines Aircraft Fueling Procedures Manual to all personnel that fuel Piedmont Airlines aircraft. This training will consist of the Piedmont Airlines Aircraft Fueling Procedures Manual (AFPM), Computer Based Training for Designated Trainers and the Piedmont Airlines Aircraft Fueling Procedures presentation for Individual Fuelers.

An employee or employees of a contracted fueling agency shall be designated by Piedmont Airlines as a Fuel Designated Trainer in Piedmont Airlines Aircraft Fueling Procedures. The Fuel Designated Trainer(s) will be trained by Computer Based Training utilizing the Learning Hub. The Fuel Designated Trainer must be able to properly service the Piedmont Airlines Aircraft him or herself and have a sound knowledge of Piedmont Airlines procedures as outlined in this manual. The Fuel Designated Trainer must be familiar with local, state and federal regulations pertaining to the fueling operation. The Fuel Designated Trainer must also be capable of instructing servicing personnel in the performance of their duties to a degree that insures a safe, efficient and competent operation.

The Aircraft Fueling Procedures Manual (AFPM), EMB-145 Aircraft Fueling Procedure Presentation, Fueler Training Record Form P_FTF02 and the Fuel Designated Trainer On-boarding form resources for vendors will be available by clicking the "Vendor" tab on the Piedmont Airlines Website at <https://piedmont-airlines.com/vendor>. The Fuel Designated Trainer will access, verify and use the current presentation for each individual Contract Fueler to be trained. It is the Fuel Designated Trainers responsibility to ensure that the most current revisions are accessible and being used. If any questions arise please contact the Piedmont Airlines Manager of Quality Assurance for assistance. The individual Contract Fueler training may be accomplished by the Piedmont Airlines Quality Assurance Department (as outline in the Maintenance Policies and Procedures Manual Chapter 16 - Quality Assurance) or an employee of the vendor who has been designated by Piedmont Airlines as a Fuel Designated Trainer in Piedmont Aircraft Fueling Procedures.

Documentation of training for both the Piedmont Airlines Fuel Designated Trainer(s) and Contract Fueling Personnel is intended to serve as verification that fuel servicing personnel who service Piedmont Airlines aircraft have received adequate training for this type of equipment which ensures they are qualified to perform these duties competently.

For the purpose of Fuel Vendor Information and Fuel Designated Trainer(s), the Piedmont Airlines Maintenance Vendor Coordinator is the point of contact..

4.1.1 Fuel Designated Trainer Training

A. Fuel Designated Trainer Training Policies;

1. Fuel Designated Trainer Training will be delivered as Computer Based Training utilizing the Learning Hub. Refer to subsections Maintenance Policies and Procedures Manual Chapter 14.4.2, "Learning Management System (LMS)" for additional policies and procedures.
2. Each of the Fuel Designated Trainer(s) will be provided with an American Airlines employee number by Identity Management (IDM) and utilized by the System Access Manager (SAM), that will allow access to the Learning Management System for training and reporting purposes.
3. Identity Management (IDM) and the System Access Manager (SAM) provides validation for each of the Fuel Designated Trainer(s). SAM provides management of the American Airlines employee number which is valid for up to a 90-day period of time, after which access will be automatically deactivated (without user action), manually deactivated or reauthorized for an additional 90-day period of time by the accountable manager.
4. The Identity Management (IDM)-assigned American Airlines employee number will remain the same regardless of which Piedmont Airlines Fuel Provider they are employed with or when the Fuel Provider is unapproved and reapproved.

Fueler Training and Documentation

30 SEP 24

5. If the Fuel Designated Trainer is inactive and reactivated but has not completed initial or recurrent training within a 24-month period, initial training will be issued.
- B. Fuel Designated Trainer Training Procedure;
1. The Manager of Quality Assurance or designee will notify the Maintenance Vendor Coordinator that a Fuel Provider is being added, deleted, deactivated or reactivated.
 2. The Maintenance Vendor Coordinator will request Identity Management (IDM) to add new Fuel Designated Trainer(s) to the System Access Manager (SAM) and to the Piedmont Airlines Maintenance domain in the Learning Hub.
 3. The Maintenance Vendor Coordinator will utilize the Identity Management (IDM) and System Access Manager (SAM) to request, deactivate or reauthorize the Fuel Designated Trainer(s).
 - a. The Maintenance Vendor Coordinator for a new or existing Fuel Vendor will;
 1. Using the standard Identity Management (IDM) and System Access Manager (SAM) controls, will request a new American Airlines employee number for each Fuel Designated Trainer(s) as collected on form "FuelVendor001". Refer to subsection Chapter 4.5 "[Form FuelVendor001, Piedmont Airlines Fuel Designated Trainer Account Request Form](#)".
 2. Enter the Fuel Designated Trainer(s) employees assigned American Airlines employee numbers for access to the Learning Hub on the Piedmont Airlines Designated Fuel Trainer Account Request form "FuelVendor001". Refer to subsection Chapter 4.5 Form FuelVendor001, Refer to subsection Chapter "[Form FuelVendor001, Piedmont Airlines Fuel Designated Trainer Account Request Form](#)".
 3. After completion of form "FuelVendor001", Refer to subsection Chapter 4.5 "[Form FuelVendor001, Piedmont Airlines Fuel Designated Trainer Account Request Form](#)" provide it to the Fuel Provider's accountable manager or point of contact.
 - b. The Maintenance Vendor Coordinator for a reactivated Fuel Provider will;
 1. Using the standard System Access Manager (SAM) controls, will reactivate the American Airlines employee number for each Fuel Designated Trainer(s) associated with the Provider.
 2. Complete the Form "FuelVendor001", Refer to subsection Chapter 4.5 "[Form FuelVendor001, Piedmont Airlines Fuel Designated Trainer Account Request Form](#)" with the Fuel Provider Fuel Designated Trainer(s) employees and assigned American Airlines employee numbers for access to the Learning Hub.
 3. After completion of Form "FuelVendor001", Refer to subsection Chapter 4.5 "[Form FuelVendor001, Piedmont Airlines Fuel Designated Trainer Account Request Form](#)" provide it to the Fuel Provider's accountable manager or point of contact.
- C. The Maintenance Vendor Coordinator will maintain the System Access Manager (SAM) account for each Fuel Designated Trainer(s) as follows:
1. By the last day of each calendar quarter, contact the Fuel Provider's accountable manager or point of contact by email or telephone to confirm the Provider and employee's status that are listed in System Access Manager.
 2. Using the standard System Access Manager (SAM) controls, will deactivate or reauthorize each Fuel Designated Trainer(s) account as applicable.
 3. Notify by email the Manager of Quality Assurance or designee of any new employee requests and deactivated accounts.
- Note •**
- Any Fuel Provider and/or Employment status changes made after the quarterly contact is completed, changes will be reflected in the next quarterly update.
- D. Fuel Designated Trainer(s) Maintenance Training Assignment progression in The Learning Hub
1. Initial Training Assignment will be automatically issued upon approval of the System Access Manager (SAM) account for each Fuel Designated Trainer(s), until completion of the initial training, the individual is not Qualified as a Fuel Designated Trainer.

Fueler Training and Documentation

30 JUL 24

2. Recurrent Training Assignment will be at a 24-month interval after the completion of the initial training.
3. Additional Training may be assigned to the Fuel Providers as appropriate, I.E. new policy change or procedural changes that affect their job duties.

4.1.2 Contract Fueling Personnel Training**A. Contract Fueling Personnel Training Policies;**

1. Contract Fueling Personnel will be trained by the Piedmont Airlines Quality Assurance Department or a Piedmont Airlines Designated Trainer utilizing the Piedmont Aircraft Fueling Procedures presentation and Piedmont Aircraft Fueling Procedures Manual. All personnel must complete initial Piedmont Airlines Fueling training before servicing Piedmont aircraft.
2. Training will be completed recurrently every 12-months after the completion of initial training.
3. Fuelers will receive initial and recurrent training covering the following topics as appropriate.
 - i. Safe operation of equipment
 - ii. Emergency procedures
 - iii. Fuel spillage avoidance response
 - iv. Aircraft fueling and defueling procedures
 - v. Aircraft specific training

B. Training Documentation

1. Documentation of training for Contract Fueling Personnel may include form "[Form P/FTF02, Piedmont Fueler Training Record](#)". The form may be copied and used freely by the fueling contractor as needed. Any combination of both Piedmont Airlines and contract agency forms may be utilized, as long as the documentation includes the equipment and procedures that are within the particular fueler's responsibilities.
2. The training documentation **MUST** be on file by the vendor at a location (electronic or paper) where it is available for inspection upon request by an American Eagle representative or other representatives of authorized agencies. This documentation must be retained for a minimum of 3 years.
3. ☞ The Manager of Quality Assurance or designee will review the fuel vendors training records every 24 months either during on-site audits or by mail / telephone requests for documentation to ensure that training has been accomplished and properly documented.

4.2 Form P/FTF02, Piedmont Fueler Training Record

P/FTF02

Rev: 14 SEP 23

PIEDMONT AIRLINES FUELER TRAINING RECORD

Aircraft Type EMB 145

Station: _____ Company Name: _____

Trainee Name: _____ Job Title: _____

Training Date: _____ Designated Trainer Phone: _____

Designated Trainer Email: _____

Rev Date of Piedmont Airlines Fueling Procedures Presentation used: _____

	Trainee Initials	Designated Trainer Initials
1) This trainee has successfully completed the Piedmont Airlines Fueling Procedures Training Presentation.		
2) This trainee has demonstrated capabilities to fuel Piedmont Airlines aircraft safely and effectively.		
3) This trainee has access to the Piedmont Airlines AFPM and understand its contents.		
4) This trainee has access to the most current revision of ATA 103.		
5) This trainee has been trained on all safety procedures regarding aircraft fueling operations and AOA regulations.		

By signing this form both the trainer and trainee acknowledge that the trainee understands the information they have been given.

Trainee Signature _____ Date _____

Designated Trainer Name: _____

Designated Trainer Signature _____ Date _____

Retain a copy of this roster for you records. The designated trainer is responsible to provide a copy of this roster when requested by Piedmont Airlines and/or applicable regulatory agency.

Form FVWR, Fuel Vendor Waiver Request

14 SEP 23

4.3 Form FVWR, Fuel Vendor Waiver Request

FVWR

[VENDOR LETTERHEAD]

[DATE]_____

AIRLINE_____

RE: REQUEST FOR WAIVER

Manual Subsection_____

Airport:_____

Effective Through_____

Dear_____:

Your airline has adopted as a part of its manual certain provisions relating to inspection tests and safety procedures which are intended to preclude the introduction of contaminated or impure fuel into the airline's aircraft. [Vendor] is unable to comply with the designated subsection of the airline's manual referenced above at the designated airport, for the following reason:

[Describe why unable to comply]

_____.

However, in order to ensure an equivalent level of fuel purity to that prescribed in the manual, [Vendor] proposes to adopt the following inspection and testing procedures at that airport until the date above when it will be in compliance with the manual:

[Describe substitute Procedures]

_____.

Accordingly,[Vendor] hereby requests that it be granted a waiver by the airline from the provision of the manual referenced above.

[Signature]

[Typed name]

[Title]

Form FVGW, Fueling Vendor Grant of Waiver

14 SEP 23

Piedmont Airlines

4.4 Form FVGW, Fueling Vendor Grant of Waiver

FVGW

AIRLINE LETTERHEAD

[DATE]_____

[VENDOR]_____

RE: GRANT OF WAIVER

Manual Subsection_____

Vendor_____

Airport_____

Effective Through_____

Dear _____:

By Letter dated _____ you have requested a waiver from the provisions of the subsection of the airline's manual referenced above with respect to operations at the specified airport. In addition, you identified procedures or tests you will substitute for those specified in the manual which you state will ensure that the requisite fuel quality and purity will be achieved.

The airline finds these procedures acceptable.

Accordingly, the airline hereby grants a waiver from the manual subsection as described in the reference above, subject to the condition that the substitute procedures or tests will remain in effect during the entire period.

[Signature]

[Typed name]

[Title]

4.5 Form FuelVendor001, Piedmont Airlines Fuel Designated Trainer Account Request Form

FuelVendor001



REV: 12/7/23

Date: _____

Piedmont Airlines Fuel Designated Trainer Account Request

Provider Information

Name of Company/Organization _____ Station Code _____

Accountable Manager/ Point of Contact Name _____ Phone Number _____ AM/POC Email _____

New Fuel Designated Trainer Information

Each Fuel Designated Trainer must provide the following information for account request and creation for a Piedmont-specific American Airlines Employee Number. Return the completed form to the Maintenance Vendor Coordinator at Piedmont Airlines. Note: AA-Assigned # to be completed by Piedmont.

Table with 5 columns: First Name, Last Name, DOB (MM/DD), Email Address, AA-Assigned #

4.6 Communications

Communications with respect to this document, and any requests for waiver of these provisions, should be addressed to:

Title: Quality Assurance Manager

Airline: Piedmont, Inc.

Address: Building 601 Airport RD
Middletown PA 17057

Phone: (717) 616-6425

E-mail: Steve.hertz@aa.com

Chapter 5: Embraer EMB-140/145 Fueling Procedures

5.1	General	5-1
5.2	Safety Conditions for the Fuel Servicing	5-1
5.3	Fuel System Fluid Tables.....	5-2
5.4	Fuel Tank Pressure Refueling / Defueling - Servicing	5-3
5.4.1	General.....	5-3
5.4.2	+Fuel Tank Pressure Refueling - Servicing.....	5-3
5.4.2.1	Pressure Refueling/Defueling fig 301	5-6
5.4.3	+Fuel Tank Defueling - Servicing	5-7
5.5	Fuel Tank Gravity Refueling / Defueling - Servicing	5-9
5.5.1	General.....	5-9
5.5.2	+Fuel Tank Gravity Refueling - Servicing.....	5-9
5.5.2.1	Gravity Fueling fig 301	5-11
5.5.3	+Fuel Tank Gravity Defueling - Servicing.....	5-12
5.5.3.1	Gravity Defueling - Installation fig 302	5-14
5.6	Fuel Tank Draining - Servicing.....	5-15
5.6.1	General.....	5-15
5.6.2	+Fuel Tank Draining - Servicing	5-15
5.6.2.1	Fuel Draining fig 301	5-17
5.7	Fuel Quantity Measuring Sticks - Servicing.....	5-18
5.7.1	General.....	5-18
5.7.2	+Fuel-Quantity Measuring Stick System (EMB-145) - Measurement.....	5-18
5.7.2.1	Table 602 - Fuel Level Measurement	5-20
5.7.2.2	Roll and Pitch Angles fig 601	5-23
5.7.2.3	Direct Measuring Points fig 602	5-24
5.7.3	+Fuel-Quantity Measuring Stick System (EMB-140) - Measurement.....	5-25
5.7.3.1	Table 602 - Fuel Level Measurement	5-27
5.7.3.2	Roll and Pitch Angles fig 601	5-30
5.7.3.3	Direct Measuring Points	5-31

Chapter 5: Embraer EMB-140/145 Fueling Procedures

5.1 General

- A. This section shows the procedures to fill/charge the aircraft systems with fuel.
- B. The main fluids used in the airplane routine services are shown in the tables below. Other fluids and products less usually necessary will be given together with the related procedures.
- C. Piedmont currently operates the EMB-145LR and EMB -135KL models only

5.2 Safety Conditions for the Fuel Servicing

WARNING

- Clothing wet with fuel must be removed immediately and the related skin area must be fully flushed. All jet fuels cause injury to the skin. Do not let these fluids touch you.
- If fuel gets into your eyes, wash the eyes immediately with a large quantity of water; then get medical services.
- Make sure that the technician is trained and prepared to do the fuel system servicing.
- For correct and careful handling of support equipment, maintenance personnel must know the system and its safety conditions.
- Do the fuel system maintenance only in an area which permits the free movement and access of firefighting equipment and persons. Make sure that fire extinguishers are available, have a minimum capacity to obey the local fire codes, and are ready to be used if there is an emergency situation.
- The area where these tasks will be done must have a good flow of air and no fuel vapor concentrations or equipment which can cause flames or sparks.
- “No Smoking” signs must be put within a radius of 50 ft (15 meters) of the operation area.
- Do not wear clothing made of in synthetic material or clothing which has metal zippers or buttons. There can be a spark.
- All persons who do these tasks must discharge the static electricity from their bodies. For this, they must touch a static ground cable or grounded object before they start the operations.
- Electrically bond all the aircraft with the correct cables.
- Use explosion-proof lamps, if an external light source is necessary.
- All external light sources must be moved away from the aircraft before the tasks are started.
- All support equipment not necessary for these tasks must be moved away for a minimum of 50 ft (15 meters) from the aircraft.
- Stop refueling procedures when lightning is detected three miles or less from fueling location. Additional, always follow local AOA and fuel vendors requirements when lightning is present.
- Make sure that no high frequency radio transmitter is operated within a radius of 200 ft (60 meters) of the aircraft or a radar equipment within a radius of 400 ft (120 meters).
- These tasks must not be done indoors or within 100 ft (30 meters) of hangars.
- The aircraft must be parked at ramp level, headed into the wind.
- Installation or removal of the batteries or associated equipment are not allowed during fueling procedures.

Fuel System Fluid Tables

13 MAR 19

- Keep the areas around the fuel tanks and vent free of vehicles and equipment, during the pressure refueling procedure.
- Do not refuel the aircraft if there is an overheat indication in the aircraft.
- Do not fill or change oxygen bottles during the refueling procedures.
- Do not start the APU during the refuel/defuel procedure after an apu automatic shutdown or failed start event occurs.
- If a fuel spillage occurs shut the APU down and do not start it.
- Prevent fuel spillage. Soak it up immediately if it occurs.
- Make sure that the fuel level in tanks is symmetrical after refueling.
- During the pressure refueling procedure, make sure that the refueling pressure is between 35 and 50 psi. An overpressure can cause damage to the equipment and injury to the persons. An under-pressure can cause unsatisfactory operation of the refueling components.
- Make sure that the fuel quantity unit is correct and reading in LBS. A wrong reading of the fuel quantity can cause an aircraft accident
- Max wing imbalance is 800lbs.

5.3 Fuel System Fluid Tables

Table 201- applicable to EMB-145LR and EMB-135LR/KL

TANKS	QUANTITY			
	LITERS		U.S. GALLONS	
	TOTAL	RESIDUAL	TOTAL	RESIDUAL
RIGHT	3,198.5	22	845	5.8
LEFT	3,198.5	22	845	5.8
TOTAL	6,397	44	1690	11.6

RESIDUAL is the fuel in the collector tank plus the undrainable one.

5.4 Fuel Tank Pressure Refueling / Defueling - Servicing

5.4.1 General

- A. This section gives the procedures to refuel/defuel the fuel tanks.
- B. The aircraft system automatically controls the operation: it stops at the correct quantity and maintains balance in the tanks, but the system must be verified throughout the fueling process by periodically verifying Left and Right tank quantities.
- C. Make sure that the fuel used comes from an approved source, which supplies only fully clean and correctly specified product.
- D. To do this procedure, use the pressure fueling adapter and the fuel control panel.
- E. Access to the fuel control panel and pressure fueling adapter is obtained got through the access door, on the right side of the fuselage, forward of wing.
- F. The fuel control panel includes a remaining fuel-quantity indicator which has an internal fuel quantity prescheduling system for the tanks. This prescheduling is done through a display operated with the related adjustment switch. These indicators are repeaters of the indicators installed on the main instrument panel.
- G. The pressure fueling adapter is assembled with a valve operated by the opening movement of the fueling nozzle shut-off valve, which is manually controlled.
- H. The pressure fueling procedure is done with the aircraft energized.

• Note •

Maximum fuel load variance is 30 gallons

5.4.2 Fuel Tank Pressure Refueling - Servicing

A. General

- I. This task gives the procedure to pressure-refuel the fuel tanks.

• Note •

- As Fuel-System Icing Inhibitors (FSII), you can use Ethylene Glycol Monomethyl Ether (EGME), which obeys MIL-I-27686 (NATO S-748), ASTM D-4171 or GOST 8313; or Di-Ethylene Glycol Monomethyl Ether (Di-EGME), which obeys MIL-I-85470A.
- You can also use the corrosion/lubricity additive found on the Qualified Product List of MIL-I-25017.
- Follow the fluid manufacturer’s specifications to find the additive proportions for each fuel.

- 2. Refer to the List of the Products Approved to be used on the Aircraft.

B. References

- Figure 301
- Figure 302

C. Access

<u>ZONE</u>	<u>PANEL/DOOR</u>	<u>LOCATION</u>
191	191BR	Wing-to-fuselage fairing

D. Tools and Equipment

Not applicable

E. Auxiliary Items

Not applicable

F. Consumable Materials

Fuel Tank Pressure Refueling / Defueling - Servicing

13 MAR 19

SPECIFICATION

<u>(BRAND)</u>	<u>DESCRIPTION</u>	<u>QTY</u>
ASTM-D-1655	JET A or JET A-1 Fuel, or other approved fuel	As Required

G. Expendable Parts
Not applicable

H. Persons Recommended

<u>QTY</u>	<u>FUNCTION</u>	<u>PLACE</u>
1	Does the task Fuel Servicing	Panel

I. Preparation

1. Obey the Safety Conditions for the Fuel Servicing.
2. Statically bond the aircraft.

• Note •

Ensure all bonding connections between the fuel source, aircraft and fuel nozzle (refer to the requirements of the Local Regulatory Authorities).

3. Energize the aircraft with the external DC power supply.

• Note •

If the external DC power supply is not available, set the POWER SELECTION switch to the BATTERY position, on the refueling panel.

4. Open access door 191BR.

J. Pressure Refueling (Figure 301)

1. For EMB-145LR and EMB -135LK aircraft models, do these steps:
 - a. Make sure that the REFUELING lights related to the LH and RH tanks are off.
 - b. Make sure that the DEFUELING light is off.
 - c. Make sure that the SELECTED quantity indicator shows zero.



Before you set the indicator, make sure of the unit of measurement (pound/kilogram) that the indicator shows.

- d. Set the indicator to the necessary fuel quantity.
- e. Remove the protective cover from the pressure refueling adapter.



Make sure that the refueling adapter is in good condition. A bad connection of the fuel nozzle can cause fuel spillage, fire, or injury to persons and damage to the equipment.

- f. Make sure that the refueling adapter is in good condition:
 - Do a check for missing or damaged lugs;
 - Do a check for signs of cracks and contamination.
- g. Connect the fuel nozzle to the pressure refueling adapter.
- h. Pressurize the system (35 - 50 psig).
- i. Make sure that there is no leakage at the fuel nozzle connection.

Fuel Tank Pressure Refueling / Defueling - Servicing

13 MAR 19

- j.* Make sure that the REFUELING lights related to the LH and RH tanks come on (CLOSED or CLSD, as applicable) and the refueling flow stops.
- k.* Set the REFUELING switch to the OPEN position and make sure that the REFUELING lights related to the LH and RH tanks go off.
- l.* Make sure that the REFUELING lights related to the LH and RH tanks come on (CLOSED or CLSD, as applicable), when you have reached the set fuel quantity.
- m.* Set the REFUELING switch to the CLOSED position.
- n.* Remove the fuel nozzle from the pressure refueling adapter.
- o.* Install the protective cover to the pressure refueling adapter.

K. Follow-on

- l.* 1. De-energize the aircraft (as required)

• Note •

If you used the POWER SELECTION switch at the BATTERY position, set it back to the NORMAL position and close the switch guard.

- 2. Remove the grounding cable from the aircraft.

WARNING

Make sure that all the switch guards are at the closed position on the refueling panel.

- 3. Close access door 191BR.

5.4.2.1 Pressure Refueling/Defueling fig 301

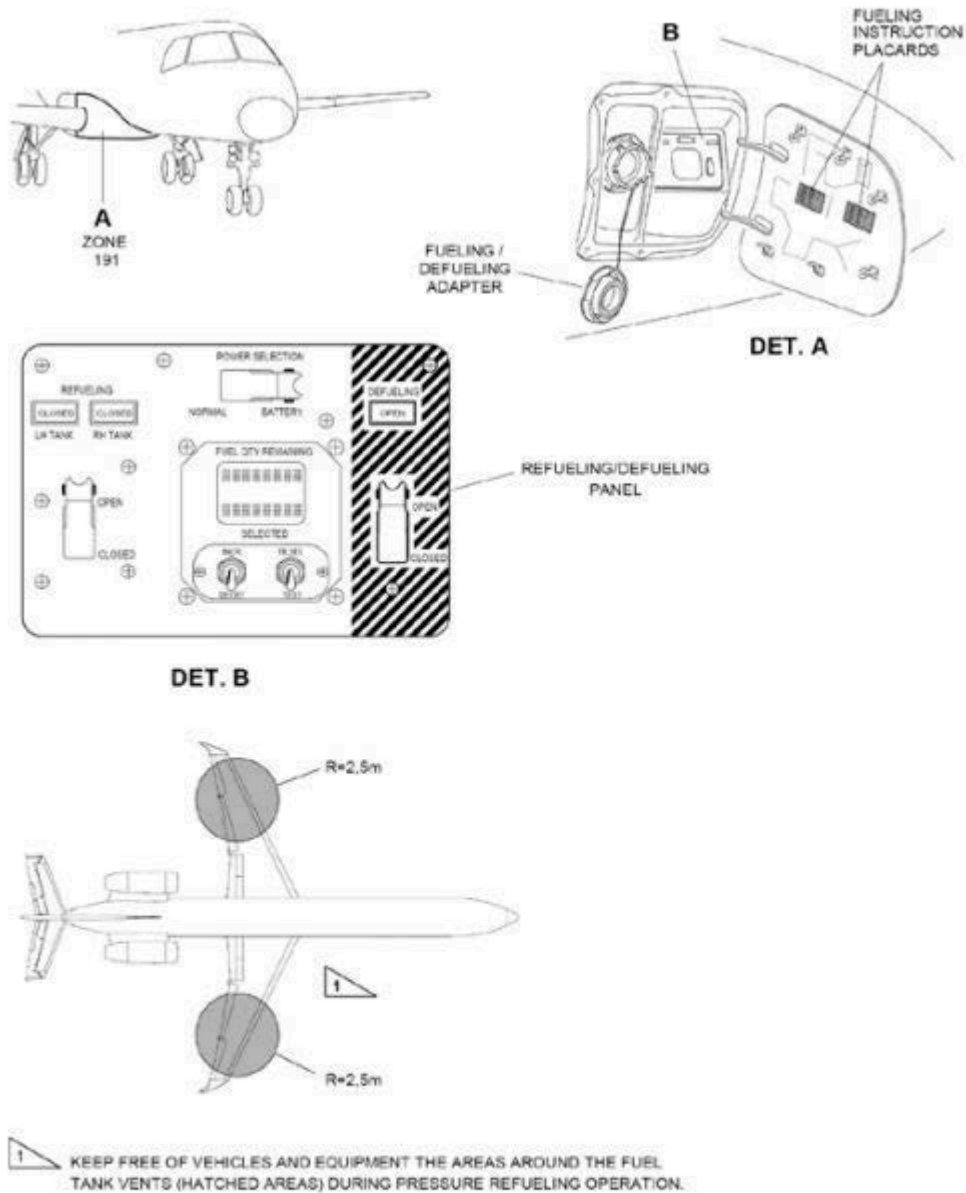

145AMM120106.MCE

Pressure Refueling/Defueling
Figure 301

5.4.3 Fuel Tank Defueling - Servicing

A. General

This task gives the procedure to defuel the fuel tanks.

B. References

- Figure 301
- Figure 302

C. Access

<u>ZONE</u>	<u>PANEL/DOOR</u>	<u>LOCATION</u>
191	191BR	Wing-to-fuselage fairing

D. Tools and Equipment

Not applicable.

E. Auxiliary Items

Not applicable.

F. Consumable Materials

Not applicable.

G. Expendable Parts

Not applicable.

H. Persons Recommended

<u>QTY</u>	<u>FUNCTION</u>	<u>PLACE</u>
1	Does the task Fuel servicing	Panel

I. Preparation.

1. Obey the Safety Conditions for the Fuel Servicing.
2. Statically bond the aircraft

• Note •

- Ensure all bonding connections between the fuel source, aircraft and fuel nozzle (refer to the requirements of the Local Regulatory Authorities).
3. Energize the aircraft with the external DC power supply.
 4. Open access door 191BR.
 5. Make sure that the DEFUELING light(s) is (are) off.
 6. Remove the protective cover from the pressure refueling adapter.
 7. Connect the fuel nozzle to the pressure refueling adapter

Fuel Tank Pressure Refueling / Defueling - Servicing

13 MAR 19

J. Pressure Defueling (figure 301)

1. For EMB-145LR and EMB-135KL aircraft models, do these steps:
 - a. . Set the DEFUELING switch to the OPEN position and make sure that the DEFUELING light comes on (OPEN).
 - b. On the overhead panel, set the XFEED switch as applicable:
 - To defuel the two tanks, set it to the LOW 2 position.
 - To defuel the LH tank, set it to the LOW 2 position.
 - To defuel the RH tank, set it to the OFF position.
 - c. Apply suction (4 psig MAX) to the nozzle or set the PUMP PWR switches, on the overhead panel, to the ON position.

• Note •

If you see that the fuel pumps “cycle” (automatically change selection of the pumps one after the other), open the circuit breakers related to the pumps not selected with the PUMP SEL switches. For example, if pumps 1A and 2B are selected, open the PUMP 1B, PUMP 1C, PUMP 2A, and PUMP 2C circuit breakers.

- d. When you have only the necessary remaining fuel quantity, set the DEFUELING switch to the CLOSED position and make sure that the light goes off.

Caution

To prevent damage, do not permit the dry operation of the fuel pumps during the defueling operation.

- e. Set the PUMP PWR and XFEED switches to the OFF position.

K. Follow-on

1. Disconnect the fuel nozzle from the pressure refueling adapter.
2. Install the protective cover to the pressure refueling adapter.
3. De-energize the aircraft.
4. Remove the bonding cable from the aircraft.

WARNING

Make sure that all the switch guards are at the closed position on the refueling panel.

5. Close access door 191BR.

5.5 Fuel Tank Gravity Refueling / Defueling - Servicing

5.5.1 General

- A. This section gives the procedures to gravity-refuel/defuel the fuel tanks.
- B. The aircraft has filler caps and defueling ports for these procedures.
- C. The fuel quantity in the tanks, during the fueling/defueling operation, is monitored from the fuel refueling panel or with the direct-measuring sticks.
- D. The defueling port is located on the undersurface of the wings or wing stub.
- E. The procedures in this section are given in the sequence below.

<u>AMTOSS No.</u>	<u>SUBJECT</u>
– TASK 12-11-02-600-801-A	Fuel Tank Gravity Refueling - Servicing
SUBTASK 12-11-02-841-001-A00	Preparation
SUBTASK 12-11-02-650-001-A00	Gravity Refueling
SUBTASK 12-11-02-842-001-A00	Follow-on
– TASK 12-11-02-600-802-A	Fuel Tank Gravity Defueling - Servicing
SUBTASK 12-11-02-841-002-A00	Preparation
SUBTASK 12-11-02-650-002-A00	Gravity Defueling
SUBTASK 12-11-02-842-002-A00	Follow-on

5.5.2 Fuel Tank Gravity Refueling - Servicing

A. General

- 1. This task gives the procedure to gravity-refuel the fuel tanks.
- 2. The tanks are gravity-refueled through the filler caps installed on the wing top surface.

• Note •

- As Fuel-System Icing Inhibitors (FSII), you can use Ethylene Glycol Monomethyl Ether (EGME), which obeys MIL-I-27686 (NATO S-748), ASTM D-4171 or GOST 8313; or Di-Ethylene Glycol Monomethyl Ether (Di-EGME), which obeys MIL-I-85470A.
- You can also use the corrosion/lubricity additive found in the Qualified Product List of MIL-I-25017.
- Follow the fluid manufacturer’s specifications to find the additive proportions for each fuel

- 3. Refer to the List of the Products Approved to be used on the Aircraft.

B. References

- Figure 301

C. Access

<u>ZONE</u>	<u>PANEL/DOOR LOCATION</u>
541	541FT Wing top surface - LH
641	641FT Wing top surface - RH

Fuel Tank Gravity Refueling / Defueling - Servicing

13 MAR 19

D. Tools and Equipment

Not applicable.

E. Auxiliary Items

<u>ITEM</u>	<u>DESCRIPTION PURPOSE</u>	<u>QTY</u>
Commercially available Ladder	For fueling	1

F. Consumable Materials

<u>SPECIFICATION (BRAND)</u>	<u>DESCRIPTION</u>	<u>QTY</u>
ASTM-D-1655	JET A or JET A-1 Fuel, or other approved fuel	AR

G. Expendable Parts

Not applicable.

H. Persons Recommended

<u>QTY</u>	<u>FUNCTION</u>	<u>PLACE</u>
1	Does the task	Wing top surface

I. Preparation

SUBTASK 12-11-02-841-001-A00

1. Obey the Safety Conditions for the Fuel and Oxygen System Servicing.
2. Statically bond the aircraft.

• Note •

- Ensure all bonding connections between the fuel source, the aircraft, and the fuel nozzle (refer to the requirements of the Local Regulatory Authorities).
- Make sure that the fueling source is with filter. If not, have a chamois-leather filter with funnel to correctly filter the fuel.

3. Install wing surface protective mat(s).
4. Open filler caps 541FT for the LH tank or 641FT for the RH tank.

J. Gravity Refueling (Figure 301)

1. Put the fueling nozzle into the filler port.
2. Start the fueling. At the same time, monitor the fuel level in the tank.
3. Remove the fueling nozzle form the filler port after you have the correct fuel level in the tank.

K. Follow-on

1. Close filler caps 541FT for the LH tank or 641FT for the RH tank.
2. Remove wing surface protective mat(s).
3. Remove the bonding cable from the aircraft.

5.5.2.1 Gravity Fueling fig 301

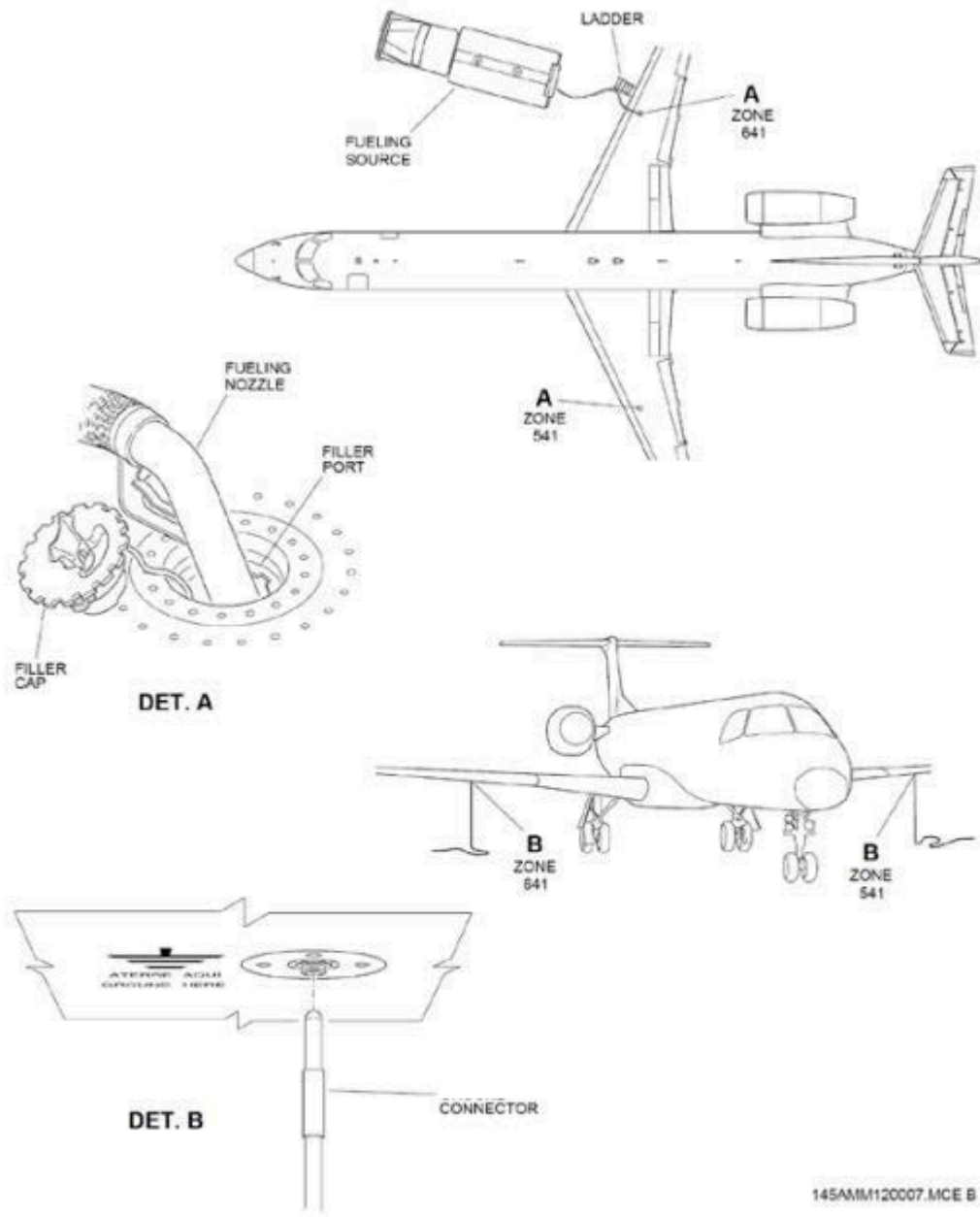

Gravity Fueling
Figure 301

5.5.3 Fuel Tank Gravity Defueling - Servicing

A. General

1. This task gives the procedure to gravity-defuel the fuel tanks.
2. The tanks are gravity-defueled through the defueling ports installed on the undersurface of the wings or wing stub.

B. References

- Figure 302

C. Access

<u>ZONE</u>	<u>PANEL/DOOR</u>	<u>LOCATION</u>
192	192AL	Wing-to-fuselage fairing undersurface - LH
192	192BR	Wing-to-fuselage fairing undersurface - RH
531	531AB	Wing undersurface - LH
631	631AB	Wing undersurface - RH

D. Tools and Equipment

<u>ITEM</u>	<u>DESCRIPTION</u>	<u>PURPOSE</u>
GSE 082	Defueling Valve	For defueling

E. Auxiliary Items

Not applicable

F. Consumable Materials

Not applicable

G. Expendable Parts

Not applicable

H. Persons Recommended

<u>QTY</u>	<u>FUNCTION</u>	<u>PLACE</u>
1	Does the task	On the undersurface of the wings or wing stub

I. Preparation

1. Obey the Safety Conditions for the Fuel and Oxygen System Servicing.
2. Statically bond the aircraft.

• Note •

Make all bonding connections between the defueling cart, the aircraft, and the defueling valve (refer to the requirements of the Local Regulatory Authorities).

3. Open the cap that is on access door 192AL or 531AB for the LH tank, or 192BR or 631AB for the RH tank.

Caution

Obey the defueling limitation related to complete aircraft jacking (AMM task 07-10-00-500-801-A).

4. Put the defueling cart near the aircraft.
- J. Gravity Defueling (Figure 302)
1. Install defueling valve GSE 082 to the defueling port.
 2. Put the other hose end into the defueling cart.
 3. Open the shutoff valve of defueling valve GSE 082 and do the defueling.

Caution

Do not operate the auxiliary fuel pumps with the tanks empty because the lack of lubrication will cause damage to them

4. When you have the quantity of fuel to be defueled, close the shutoff valve of defueling valve GSE 082.
 5. Remove defueling valve GSE 082 from the defueling port.
- K. Follow-on
1. Remove the defueling cart away from the aircraft.
 2. Close the cap that is on access door 192AL or 531AB for the LH tank, or 192BR or 631AB for the RH tank.
 3. Remove the bonding cable from the aircraft.

5.5.3.1 Gravity Defueling - Installation fig 302

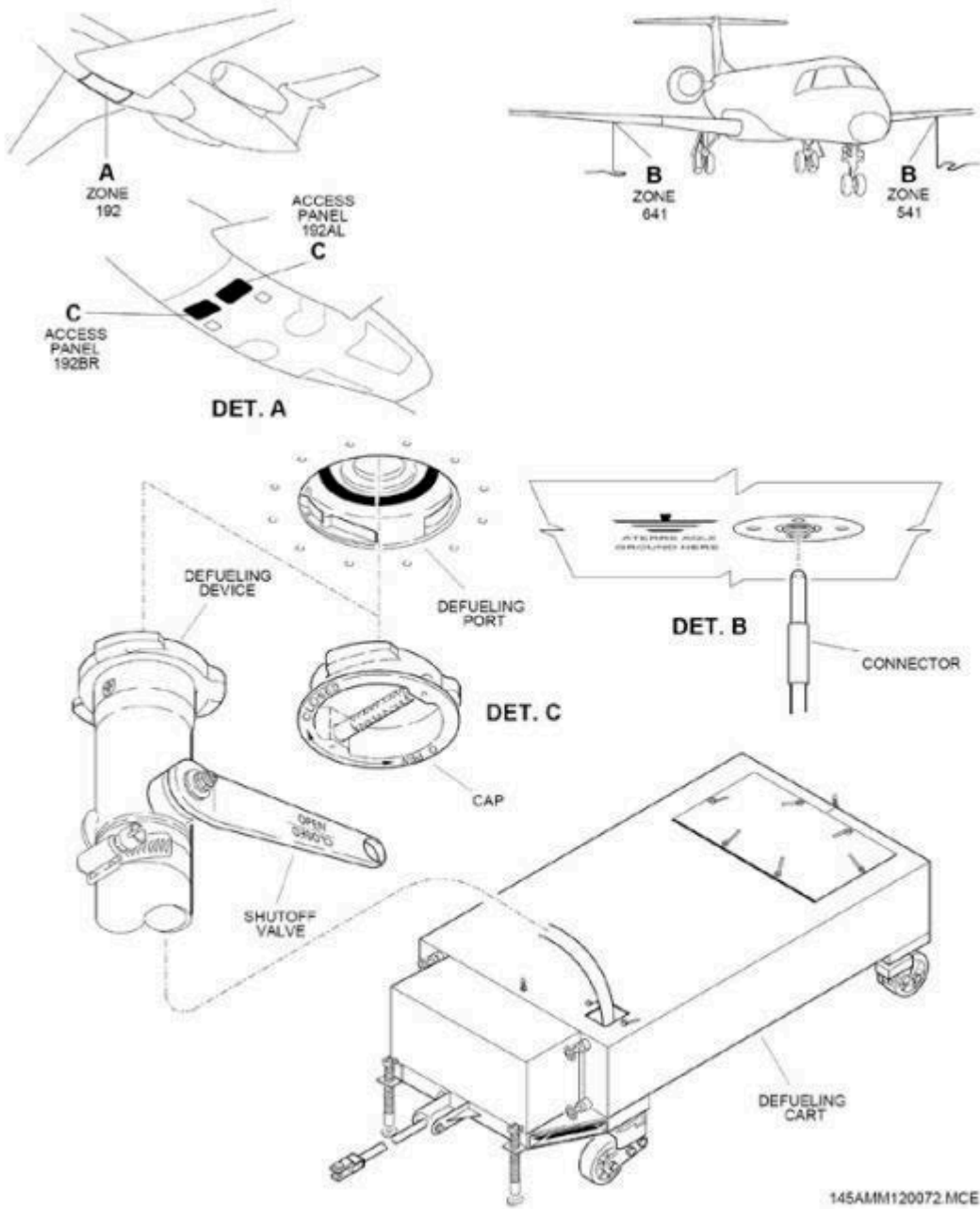

Gravity Defueling - Installation
Figure 302

5.6 Fuel Tank Draining - Servicing

5.6.1 General

- A. This section gives the procedures to drain the fuel tanks.
- B. The fuel tanks are drained through the drain valves installed at the lowest part of the inboard tanks.
- C. You must drain the fuel tanks periodically to remove free water and other types of contamination that come with the fuel and stay in the lowest part of the tanks.
- D. The fuel lines are drained through drain valves installed in the cross-feed line, pressure fueling lines, and ventilation fuel lines. These fuel lines are drained for servicing and maintenance only.
- E. Refer to AMM TASK 28-11-00-300-801-A for control, prevention, and treatment of corrosion caused by microorganisms.
- F. The procedures in this section are given in the sequence below. The tasks identified with (") are part of the Scheduled Maintenance Requirements Document (SMRD).

<u>AMTOSS No.</u>	<u>SUBJECT</u>
TASK 12-11-03-600-801-A	Fuel Tank Draining - Servicing
SUBTASK 12-11-03-841-001-A00	Preparation
SUBTASK 12-11-03-680-001-A00	Drain Fuel Tanks to Check for the Pressure of Water
SUBTASK 12-11-03-842-001-A00	Follow-on

5.6.2 Fuel Tank Draining - Servicing

- A. General
 - 1. Drain fuel from each tank and examine it for water and other unwanted matter. You will usually see the water as a layer below the fuel or as small bubbles on the fuel.
 - 2. Let the water go down apart from the fuel before you drain it.

- B. References
 - Figure 301

C. Access

<u>ZONE</u>	<u>PANEL/DOOR</u>	<u>LOCATION</u>
192	192CL	Center lower fairing
192	192DR	Center lower fairing
192	192HL	Center lower fairing (LR/LU/KL versions)
192	192JR	Center lower fairing (LR/LU/KL versions)

D. Tools and Equipment

<u>ITEM</u>	<u>DESCRIPTION</u>	<u>PURPOSE</u>
GSE 016	Draining Device	To collect the drained fuel

E. Auxiliary Items

<u>ITEM</u>	<u>DESCRIPTION / PURPOSE</u>	<u>QTY</u>
Commercially available Transparent flask	To collect the drained fuel	1

- F. Consumable Materials
 - Not applicable.
- G. Expendable Parts
 - Not applicable.
- H. Persons Recommended

Fuel Tank Draining - Servicing

13 MAR 19

<u>QTY</u>	<u>FUNCTION</u>	<u>PLACE</u>
1	Does the task	Bottom of the inboard tanks

I. Preparation

1. Open access panel 192CL or 192DR.
2. Open access panel 192HL or 192JR (LR/LU/KL versions).

J. Drain Fuel Tanks to Check for the Presence of Water (Figure 301)

1. . Put the draining device with the flask below the drain valve.

Caution

To open the drain valve, do not turn the draining device clockwise. It can cause damage to the drain valve.

2. Open the drain valve with the draining device. To do this, push the draining device and give it onequarter turn counterclockwise.

• Note •

Drain many times, until the fuel in the container is free of water. Examine the collected fuel for contamination, especially at the fuel/water interface.

3. When the procedure is completed, close the drain valve. To do this, give it one-quarter turn in the opposite direction.
4. Do steps (1), (2), and (3) again for the other tank drain valve.

K. Follow-on

1. Close access panel 192CL or 192DR.
2. Close access panel 192HL or 192JR(LR/LU/KL versions).

5.6.2.1 Fuel Draining fig 301

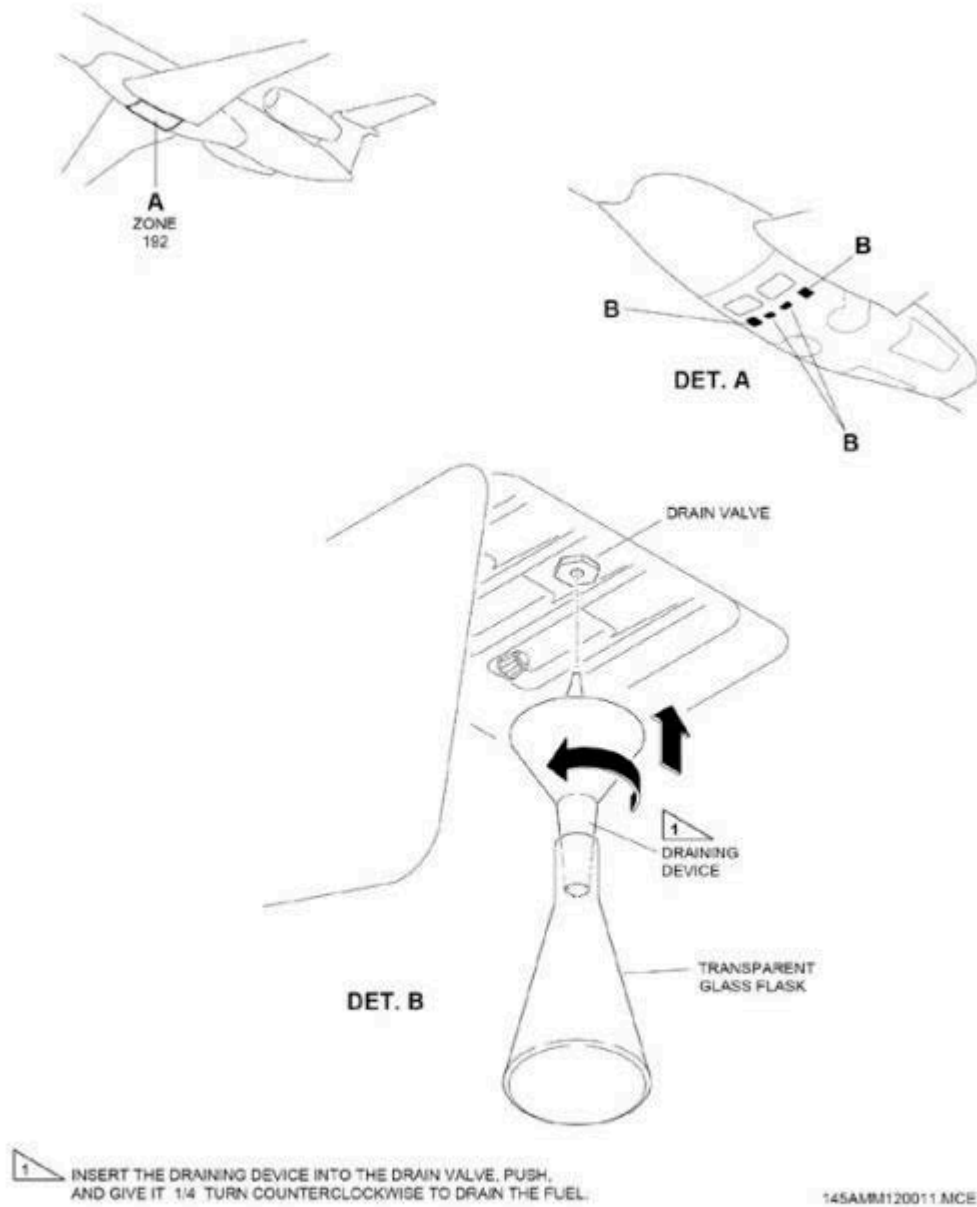

Fuel Draining
Figure 301

5.7 Fuel Quantity Measuring Sticks - Servicing

5.7.1 General

- A. This section gives the procedure to do a manual measuring of the fuel quantity in each fuel tank.
- B. The procedures in this section are given in the sequence below.

<u>AMTOSS No.</u>	<u>SUBJECT</u>
Task 12-11-04-700-802-A	Fuel-Quantity Measuring Stick System - Measurement
SUBTASK 12-11-04-841-002-A00	Preparation
SUBTASK 12-11-04-750-002-A00	Fuel Level Measurement
SUBTASK 12-11-04-842-002A00	Follow-on

5.7.2 Fuel-Quantity Measuring Stick System (EMB-145) - Measurement

Effectivity: EMB-145LR

- A. General
 - 1. The fuel-measuring stick assemblies are on the wing and wing-stub lower surface. There are two of them in each half-wing and two in the wing stub.
 - 2. Each measuring point has a magnetic float, which holds a calibrated stick. When it is at the fuel level, the stick gives a visual indication of the total fuel quantity on the related side.

- B. References
 - Figure 601
 - Figure 602

C. Access

<u>ZONE</u>	<u>PANEL/DOOR</u>	<u>LOCATION</u>
500		Left half-wing
600		Right half-wing
155		Wing stub - LH
156		Wing stub - RH

D. Tools and Equipment

Not applicable

E. Auxiliary Items

Not applicable

F. Consumable Materials

Not applicable

G. Expendable Parts

Not applicable

H. Persons Recommended

<u>QTY</u>	<u>FUNCTION</u>	<u>PLACE</u>
1	Does the task	On the half-wings and wing stub

I. Preparation

- 1. Make sure that the aircraft is safe for maintenance.
- 2. Do not do other tasks on the aircraft because it will cause error in the stick position measurement.
- 3. Energize the aircraft.

Fuel Quantity Measuring Sticks - Servicing

13 MAR 19

• Note •

After the aircraft refueling or the deactivation of the fuel pumps, it is necessary to stop for a minimum of 10 minutes and then make the reading.

4. The aircraft must be laterally leveled (roll and pitch angles) as follows (Figure 601):
 - a. Make sure that the roll angle is 0° to -2° and the pitch angle is $-1^{\circ} \pm 1^{\circ}$.
 - b. Use the RA knob, on the DC-550 display controller (pilot or copilot side), and set the DH (decision height) to "90".
 - c. Push the RA test button and ET pushbutton, on the DC-550 display controller, at the same time and for a minimum of 10 seconds.
 - d. The PFD display will show the pitch and roll values.

• Note •

If not, it will be necessary to maneuver the aircraft and park it at the necessary parking position to have the correct roll and pitch angle limits.

J. Fuel Level Measurement (Figure 602)

1. At the wing undersurface, turn the stick latch counterclockwise to release the stick from the housing and permit it to fall.

• Note •

To determine the fuel quantity in one of the wings, start the measurements from the wing tip and go in the direction of the wing root, until you have a point which is not at the lower stop (²zero² reading on the scale). The value found must then be entered in Table 602.

2. After the fuel reading, reinsert and secure the stick in its housing.

Fuel Quantity Measuring Sticks - Servicing

13 MAR 19

5.7.2.1 Table 602 - Fuel Level Measurement

Table 602 - Fuel Level Measurement

STICK INDICATION	FUEL QUANTITY (USABLE) ^[2]					
	STICK 1 (wing stub)		STICK 2 (wing root)		STICK 3 (wing tip)	
	LITERS	US GAL	LITERS	US GAL	LITERS	US GAL
0.1	7	2	781	206	2163	571
0.2	14	4	794	210	2184	577
0.3	22	6	805	213	2203	582
0.4	29	8	817	216	2220	586
0.5	36	10	827	219	2235	590
0.6	43	11	838	221	2249	594
0.7	50	13	848	224	2263	598
0.8	56	15	858	227	2276	601
0.9	63	17	868	229	2288	605
1.0	69	18	878	232	2301	608
1.1	74	20	888	235	2314	611
1.2	80	21	898	237	2327	615
1.3	85	23	907	240	2340	618
1.4	90	24	917	242	2354	622
1.5	95	25	927	245	2368	626
1.6	100	26	937	248	2383	630
1.7	104	28	947	250	2398	633
1.8	109	29	957	253	2413	638
1.9	113	30	968	256	2429	642
2.0	116	31	978	258	2445	646
2.1	120	32	989	261	2461	650
2.2	123	33	1000	264	2477	654
2.3	129	34	1011	267	2493	659
2.4	136	36	1022	270	2508	663
2.5	140	37	1034	273	2524	667
2.6	144	38	1045	276	2539	671
2.7	148	39	1057	279	2553	674
2.8	155	41	1069	282	2567	678
2.9	164	43	1081	286	2580	682
3.0	173	46	1093	289	2593	685
3.1	181	48	1105	292	2604	688
3.2	188	50	1118	295	2615	691
3.3	195	51	1130	299	2625	693
3.4	201	53	1143	302	2634	696
3.5	207	55	1156	305	2643	698
3.6	213	56	1169	309	2651	700
3.7	218	58	1182	312	2658	702
3.8	224	59	1194	316	2666	704
3.9	229	60	1208	319	2673	706
4.0	234	62	1221	322	2680	708
4.1	239	63	1234	326	2687	710
4.2	244	64	1247	329	2696	712
4.3	249	66	1260	333	2706	715
4.4	254	67	1273	336	2717	718

Fuel Quantity Measuring Sticks - Servicing

13 MAR 19

Continued

STICK INDICATION	FUEL QUANTITY (USABLE) ^[2]					
	STICK 1 (wing stub)		STICK 2 (wing root)		STICK 3 (wing tip)	
	LITERS	US GAL	LITERS	US GAL	LITERS	US GAL
4.5	259	68	1286	340	2731	721
4.6	265	70	1300	343	2747	726
4.7	270	71	1313	347	2767	731
4.8	276	73	1326	350	2791	737
4.9	281	74	1339	354		
5.0	287	76	1352	357		
5.1	293	78	1365	361		
5.2	300	79	1378	364		
5.3	306	81	1391	368		
5.4	313	83	1404	371		
5.5	320	85	1418	374		
5.6	327	86	1431	378		
5.7	334	88	1444	381		
5.8	342	90	1457	385		
5.9	350	92	1470	388		
6.0	357	94	1483	392		
6.1	365	97	1496	395		
6.2	374	99	1509	399		
6.3	382	101	1522	402		
6.4	390	103	1535	405		
6.5	399	105	1548	409		
6.6	408	108	1561	412		
6.7	416	110	1574	416		
6.8	425	112	1588	419		
6.9	434	115	1601	423		
7.0	443	117	1615	427		
7.1	452	119	1629	430		
7.2	461	122	1642	434		
7.3	470	124	1656	438		
7.4	479	126	1670	441		
7.5	488	129	1685	445		
7.6	497	131	1699	449		
7.7	505	134	1714	453		
7.8	514	136	1729	457		
7.9	523	138	1744	461		
8.0	532	141	1759	465		
8.1	541	143	1774	469		
8.2	550	145	1790	473		
8.3	558	147	1806	477		
8.4	567	150	1822	481		
8.5	576	152	1838	486		
8.6	585	154	1855	490		
8.7	593	157	1872	494		

Fuel Quantity Measuring Sticks - Servicing

13 MAR 19

Continued

Table 602 - Fuel Level Measurement (Continued)

STICK INDICATION	FUEL QUANTITY (USABLE) ^[2]					
	STICK 1 (wing stub)		STICK 2 (wing root)		STICK 3 (wing tip)	
	LITERS	US GAL	LITERS	US GAL	LITERS	US GAL
8.8	602	159	1889	499		
8.9	611	161	1906	503		
9.0	620	164	1923	508		
9.1	629	166	1941	513		
9.2	639	169	1958	517		
9.3	648	171	1976	522		
9.4	658	174	1994	527		
9.5	668	176	2012	531		
9.6	679	179	2030	536		
9.7	689	182	2048	541		
9.8	701	185	2065	546		
9.9	713	188	2083	550		
10.0	725	192	2101	555		
10.1	738	195	2118	560		
10.2	752	199	2135	564		
10.3	767	203	2152	568		
10.4	783	207	2168	573		

[2] (Roll : 0° to -2°; Pitch: -1° ± 1°)

K. Follow-on

De-energize the aircraft.

5.7.2.2 Roll and Pitch Angles fig 601

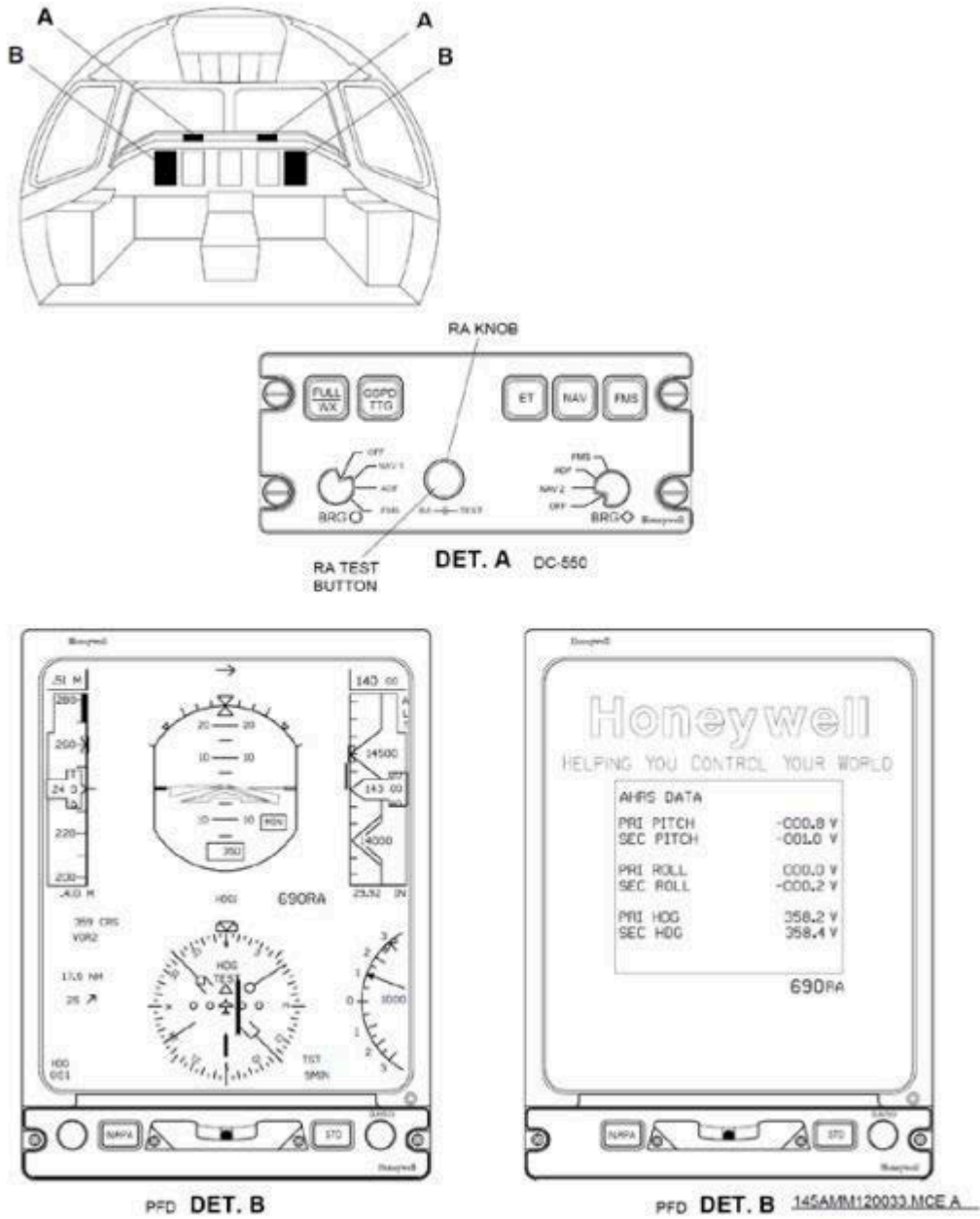

Roll and Pitch Angles
 Figure 601

5.7.2.3 Direct Measuring Points fig 602

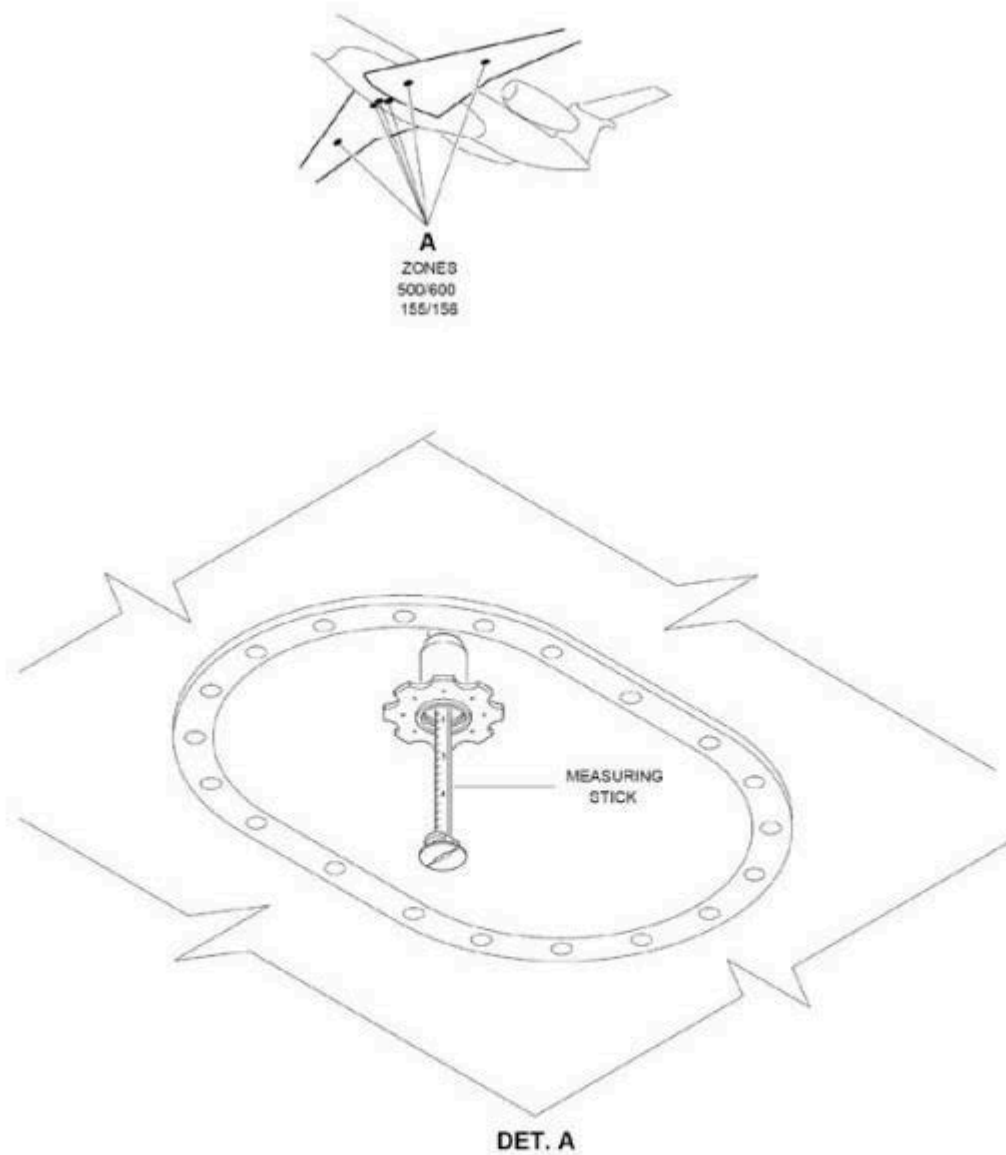

145AMM120034 MCE C

Direct Measuring Points
Figure 602

Fuel Quantity Measuring Sticks - Servicing

13 MAR 19

5.7.3 Fuel-Quantity Measuring Stick System (EMB-140) - Measurement

EFFECTIVITY: EMB-145LR/LU/XR AND EMB-135LR/KL MODELS

Fuel- Quantity Measuring Stick System - Measurement

A. General

1. The fuel-measuring stick assemblies are on the wing and wing-stub lower surface. There are two of them in each half-wing and two in the wing stub.
2. Each measuring point has a magnetic float, which holds a calibrated stick. When it is at the fuel level, the stick gives a visual indication of the total fuel quantity on the related side.

B. References

- AMM 12-11-04/601
- Figure 601
- Figure 602
- TASK 20-40-01-860-801-A

C. Access

<u>ZONE</u>	<u>PANEL/DOOR</u>	<u>LOCATION</u>
500		Left half-wing
600		Right half-wing
155		Wing stub - LH
156		Wing stub - RH

D. Tools and Equipment

Not applicable.

E. Auxiliary Items

Not applicable.

F. Consumable Materials

Not applicable.

G. Expendable Parts

Not applicable.

Fuel Quantity Measuring Sticks - Servicing

13 MAR 19

H. Persons Recommended

QTY
1

FUNCTION
Does the task

PLACE
on the half-wings and wing stub

I. Preparation

1. Make sure that the aircraft is safe for maintenance.
2. Do not do other tasks on the aircraft because it will cause error in the stick position measurement.
3. Energize the aircraft.

• Note •

After the aircraft refueling or the deactivation of the fuel pumps, it is necessary to stop for a minimum of 10 minutes and then make the reading.

4. The aircraft must be laterally leveled (roll and pitch angles) as follows (Figure 601):
 - a. Make sure that the roll angle is 0° to -2° and the pitch angle is $-1^{\circ} \pm 1^{\circ}$.
 - b. Use the RA knob, on the DC-550 display controller (pilot or copilot side), and set the DH (decision height) to 2690° .
 - c. Push the RA test button and ET pushbutton, on the DC-550 display controller, at the same time and for a minimum of 10 seconds.
 - d. The PFD display will show the pitch and roll values

• Note •

If not, it will be necessary to maneuver the aircraft and park it at the necessary parking position to have the correct roll and pitch angle limits.

J. Fuel Level Measurement (Figure 602)

SUBTASK 12-11-04-750-002-A00

1. At the wing undersurface, turn the stick latch counterclockwise to release the stick from the housing and permit it to fall. Piedmont

• Note •

To determine the fuel quantity in one of the wings, start the measurements from the wing tip and go in the direction of the wing root, until you have a point which is not at the lower stop (2 zero 2 reading on the scale). The value found must then be entered in table 602.

Fuel Quantity Measuring Sticks - Servicing

13 MAR 19

5.7.3.1 Table 602 - Fuel Level Measurement

Table 602 - Fuel Level Measurement

STICK INDICATION	FUEL QUANTITY (USABLE) ^[2]					
	STICK 1 (wing stub)		STICK 2 (wing root)		STICK 3 (wing tip)	
	LITERS	US GAL	LITERS	US GAL	LITERS	US GAL
0.1	7	2	781	206	2163	571
0.2	14	4	794	210	2184	577
0.3	22	6	805	213	2203	582
0.4	29	8	817	216	2220	586
0.5	36	10	827	219	2235	590
0.6	43	11	838	221	2249	594
0.7	50	13	848	224	2263	598
0.8	56	15	858	227	2276	601
0.9	63	17	868	229	2288	605
1.0	69	18	878	232	2301	608
1.1	74	20	888	235	2314	611
1.2	80	21	898	237	2327	615
1.3	85	23	907	240	2340	618
1.4	90	24	917	242	2354	622
1.5	95	25	927	245	2368	626
1.6	100	26	937	248	2383	630
1.7	104	28	947	250	2398	633
1.8	109	29	957	253	2413	638
1.9	113	30	968	256	2429	642
2.0	116	31	978	258	2445	646
2.1	120	32	989	261	2461	650
2.2	123	33	1000	264	2477	654
2.3	129	34	1011	267	2493	659
2.4	136	36	1022	270	2508	663
2.5	140	37	1034	273	2524	667
2.6	144	38	1045	276	2539	671
2.7	148	39	1057	279	2553	674
2.8	155	41	1069	282	2567	678
2.9	164	43	1081	286	2580	682
3.0	173	46	1093	289	2593	685
3.1	181	48	1105	292	2604	688
3.2	188	50	1118	295	2615	691
3.3	195	51	1130	299	2625	693
3.4	201	53	1143	302	2634	696
3.5	207	55	1156	305	2643	698
3.6	213	56	1169	309	2651	700
3.7	218	58	1182	312	2658	702
3.8	224	59	1194	316	2666	704
3.9	229	60	1208	319	2673	706
4.0	234	62	1221	322	2680	708
4.1	239	63	1234	326	2687	710
4.2	244	64	1247	329	2696	712
4.3	249	66	1260	333	2706	715
4.4	254	67	1273	336	2717	718

Fuel Quantity Measuring Sticks - Servicing

13 MAR 19

Continued

STICK INDICATION	FUEL QUANTITY (USABLE) ^[2]					
	STICK 1 (wing stub)		STICK 2 (wing root)		STICK 3 (wing tip)	
	LITERS	US GAL	LITERS	US GAL	LITERS	US GAL
4.5	259	68	1286	340	2731	721
4.6	265	70	1300	343	2747	726
4.7	270	71	1313	347	2767	731
4.8	276	73	1326	350	2791	737
4.9	281	74	1339	354		
5.0	287	76	1352	357		
5.1	293	78	1365	361		
5.2	300	79	1378	364		
5.3	306	81	1391	368		
5.4	313	83	1404	371		
5.5	320	85	1418	374		
5.6	327	86	1431	378		
5.7	334	88	1444	381		
5.8	342	90	1457	385		
5.9	350	92	1470	388		
6.0	357	94	1483	392		
6.1	365	97	1496	395		
6.2	374	99	1509	399		
6.3	382	101	1522	402		
6.4	390	103	1535	405		
6.5	399	105	1548	409		
6.6	408	108	1561	412		
6.7	416	110	1574	416		
6.8	425	112	1588	419		
6.9	434	115	1601	423		
7.0	443	117	1615	427		
7.1	452	119	1629	430		
7.2	461	122	1642	434		
7.3	470	124	1656	438		
7.4	479	126	1670	441		
7.5	488	129	1685	445		
7.6	497	131	1699	449		
7.7	505	134	1714	453		
7.8	514	136	1729	457		
7.9	523	138	1744	461		
8.0	532	141	1759	465		
8.1	541	143	1774	469		
8.2	550	145	1790	473		
8.3	558	147	1806	477		
8.4	567	150	1822	481		
8.5	576	152	1838	486		
8.6	585	154	1855	490		
8.7	593	157	1872	494		

Continued

Table 602 - Fuel Level Measurement (Continued)

STICK INDICATION	FUEL QUANTITY (USABLE) ^[2]					
	STICK 1 (wing stub)		STICK 2 (wing root)		STICK 3 (wing tip)	
	LITERS	US GAL	LITERS	US GAL	LITERS	US GAL
8.8	602	159	1889	499		
8.9	611	161	1906	503		
9.0	620	164	1923	508		
9.1	629	166	1941	513		
9.2	639	169	1958	517		
9.3	648	171	1976	522		
9.4	658	174	1994	527		
9.5	668	176	2012	531		
9.6	679	179	2030	536		
9.7	689	182	2048	541		
9.8	701	185	2065	546		
9.9	713	188	2083	550		
10.0	725	192	2101	555		
10.1	738	195	2118	560		
10.2	752	199	2135	564		
10.3	767	203	2152	568		
10.4	783	207	2168	573		

[2] (Roll : 0° to -2°; Pitch: -1° ± 1°)

(2.) After the fuel reading, close the stick in its housing.

K. Follow-on

SUBTASK 12-11-04-842-002-A00.

I. De-energize the aircraft (TASK 20-40-01-860-801-A.)

5.7.3.2 Roll and Pitch Angles fig 601

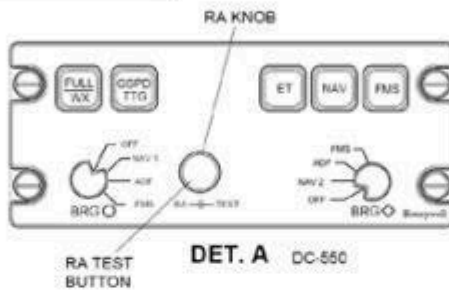
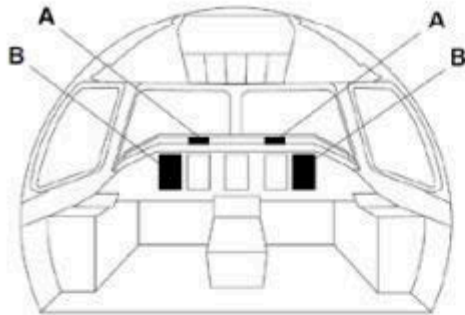

Roll and Pitch Angles
 Figure 601

5.7.3.3 Direct Measuring Points

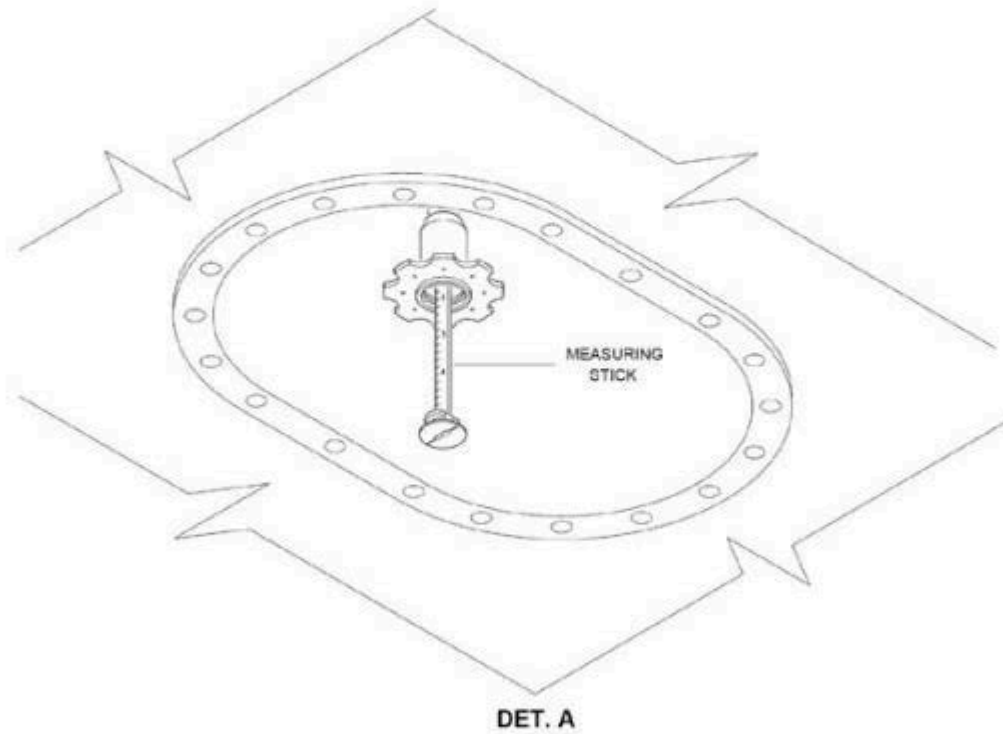
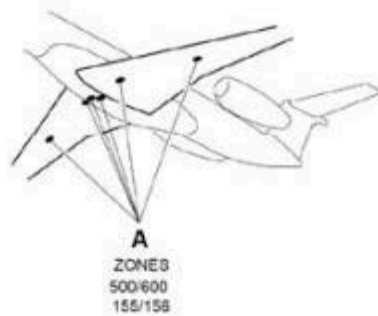

145AMM120034 MCE C

Direct Measuring Points
Figure 602